

SERIAL #

SST/Racer[®] OWNERS MANUAL

Racer/Elite[™], SST/Racer, Racer/Trainer, Racer/Tandem, Racer/Tactical

PARACHUTE LABORATORIES INC.

d.b.a. JUMP SHACK

1665 LEXINGTON AVE.

SUITE 106

DELAND, FL. USA

32724

Art work by Nancy LaRiviere & Sandy Williams

Table of Contents

GENERAL.....	3	SST/TRAINER ASSEMBLY	16
INTRODUCTION	3	INSTRUCTION FOR CHANGING FROM STATIC LINE	
WARNING	3	TO PILOT CHUTE WITHOUT UNPACKING THE	
DISCLAIMER	3	BAG.	17
ABOUT THE MANUAL	4	MAIN ASSEMBLY	17
COPYRIGHTS	4	RESERVE PACKING INSTRUCTIONS.....	18
SERIAL NUMBER	4	GENERAL	18
OPERATIONAL LIMITATIONS	5	CRITICAL POINTS	18
TECHNICAL DATA	5	REQUIRED TOOLS	18
MODIFYING YOUR SST	5	PART ONE: PREPARATION	18
COMPATIBILITY	5	PILOT CHUTE, CLOSING LOOP (QUICK LOOP) & HAT	18
OPERATIONAL CHARACTERISTICS	7	PART TWO: PACKING	19
GENERAL DESCRIPTION	7	PACKING TYPE I & II	20
THE MAIN SYSTEM	7	PACKING TYPE IV	21
1. Ripcord Deployment	7	PACKING TYPE V	21
2. Pullout Hand Deployment	7	PART THREE: CLOSING THE CONTAINER	28
3. Throw-out Hand Deployment	7	TACKING QUICK LOOP	30
4. Automatic Activation	7	DRESSING THE CONTAINER	30
5. Static-line Deployment	8	MAIN PACKING INSTRUCTIONS.....	32
THE RESERVE SYSTEM	8	SETTING BRAKES	32
1. Ripcord Deployment	8	FLAG SLIDER INSTRUCTIONS	32
2. Reserve Lanyard	8	PLACING CANOPY INTO BAG	32
3. Automatic Activation	8	PLACING BAG INTO CONTAINER	33
AAD SET-UP NOTIFICATION	9	FOR PULL-OUT	33
THE MAIN CANOPY RELEASE SYSTEM	9	FOR THROW-OUT	34
THE SST TRAINER SYSTEM	9	FOR RIPCORD	36
WHAT YOU SHOULD KNOW ABOUT		FOR STATIC LINE	36
RESERVE STATIC LINES	9	DRESSING THE CONTAINER	37
The Drogue System	10	Tandem Drogue & Main Container Closing	38
INSPECTION INSTRUCTIONS.....	12	Closing The Main Container	38
CYCLIC INSPECTIONS	12	First Level Closing	38
PRE-JUMP INSPECTION	12	Bridle Release Assembly	39
MAINTENANCE/REPAIR.....	13	Second Level Closing	40
PERSONNEL QUALIFICATIONS	13	DONNING THE SST.....	42
MAINTENANCE PROCEDURES	13	WITH THREAD THROUGH LEG STRAPS	42
MAIN CLOSING LOOP REPLACEMENT &		WITH B-12 LEG STRAP SNAPS	42
ADJUSTMENT	13	FAMILIARIZATION	43
REPAIR PROCEDURES	13	MAIN ACTIVATION	43
ASSEMBLY.....	15	PULL-OUT	43
PERSONNEL QUALIFICATIONS	15	THROW-OUT	43
PARTS LIST	15	RIPCORDER	44
RESERVE ASSEMBLY	15	CUTAWAY ACTIVATION	44
TANDEM CANOPY ASSEMBLY	16	RESERVE ACTIVATION	44

GENERAL

INTRODUCTION

Congratulations on the purchase of your new SST/Racer, Racer/Elite™ or Elite/TRAINER or Tandem. As you put jumps on your new rig and get to know it, you will come to realize that you have purchased the most exquisite piece of parachute equipment that money can buy. We are sure that it is the most thoroughly engineered harness and container system available.

Note, if you will, our attention to details such as our use of type 13 webbing, the only webbing approved for use with parachute hardware. The new Elite™ minimizes the use of velcro, but where velcro is used it is easily serviced. We've paid attention to other details like the finished end on the chest strap, but many features of the SST will escape your first glance.

We started building SSTs when the idea of “piggy-back” meant literally snapping a reserve to your back above the main container. We developed and were the first to employ the hot knifed single piece construction technique now used by all of the other manufacturers. Now after 25 years and 30,000 Racers, our basic design has not had to change. It was ahead of its time when it was conceived and it still is. So while other manufacturers have had to undergo recalls and major design changes in an effort to “get it right” the SST has endured. Even our competitors have said of the Racer, “Sherman got it right the first time”.

When you examine the new Racer/Elite™ closely you will find the basic workings of the rig haven't changed at all, we've just made it simpler and more attractive! We have refined the SST from the most time-proven design in parachuting. It's funny, but not that much needed changing. We *did* get it right the first time.

As parachutes got smaller, we trimmed the SST to the familiar wedge shape of the Racer. The 3-Ring release became available, so we designed it into the system. Skydivers demanded hand deployment, so we gave them the choice of either type, pull-out or throw-out, while retaining the ripcord option for students.

Modern canopies had become so small, the harness could no longer brace against the pack for fit. The new age called for a truly integral harness and container system that fit more like a tailored coat than a hiker's backpack.

That's how your new Racer, Racer/Elite™ or Elite/TRAINER came to be. And yet, it still is an SST. We alone offer the superior Pop-Top reserve system, and we still make SSTs for the jumper who demands gear from the cutting edge of skydiving technology. This manual introduces you to your new SST/Racer, Racer/Elite™, or Elite/TRAINER or Tandem—An introduction you must have before taking to the air with it. So leave yourself plenty of time between getting the rig and making the first jump on it. Use this manual to help familiarize yourself with the system. You can get thousands of jumps from a well maintained SST, so there's no need to rush to the first one.

WARNING

IT IS ASSUMED THAT INTENTIONALLY JUMPING FROM AN AIRPLANE IN FLIGHT OR FROM A FIXED OBJECT IS DANGEROUS TO LIFE AND LIMB. PARACHUTES DO NOT ALWAYS WORK AS DESIRED. WHEN YOU TAKE IT UPON YOURSELF TO PARTICIPATE IN PARACHUTE JUMPING, YOU ACCEPT THE FACT THAT NO MATTER HOW CAREFUL YOU ARE, OR HOW GOOD YOUR EQUIPMENT IS, YOU CAN BE SERIOUSLY OR FATALLY INJURED.

WARNING—NO WARRANTIES

DISCLAIMER

It is expressly understood and agreed between the seller and the buyer and any subsequent user of the SST, all or in part, the manufacturer and seller shall in no way be deemed or held liable or accountable for any failure or damages resulting from failure of the

SST. Use of the SST for any purpose shall constitute waiver to the manufacturer and seller for any damages to person or property directly or indirectly caused by said use. The SST is sold with all faults and without fitness for any particular purpose, and the manufacturer neither implies or expresses any warranties or guarantees of the SST. Use of this rig for any purpose constitutes agreement between the buyer or user and the seller according to the terms herein. If the buyer refuses the terms of this agreement, he must return the unused SST to the manufacturer with 10 days of receipt of the SST with a letter stating why the SST was returned along with the original invoice showing purchase price.

ABOUT THE MANUAL

We have tried to write this, the sixth edition of this manual, for all SSTs. However, it is only current for the serial number shown on the first page. The data contained herein was current at the time of this writing, but the sport advances rapidly. Some of this information may not be true now or especially as time goes on. We reserve the right to change the SST and its procedures without notice. Prudence requires that you contact us for information on updates if you are using this manual as a guide to service a later generation SST. Additionally, you may view our most recent version at our Internet site WWW.JUMPSHACK.COM

COPYRIGHTS

Jump Shack holds all copyrights to this manual. We grant permission to anyone to reproduce it all or in part for non-commercial purposes. No reproduction of this manual may be sold anywhere without a royalty agreement with Jump Shack. Anyone copying this manual for distribution must do so without charge, excepting the cost of reproduction.

SERIAL NUMBER

The first two digits of the serial number denote the week of manufacture. The third digit denotes the year. The last two digits denote the sequence.

Caution: This manual is serial numbered corresponding to the SST with which it was shipped. Technical

information in this manual refers only to the SST of that same serial number.

Record the information from the data plate now, along with the colors of your SST, in case your gear becomes lost or stolen. Also record the serial numbers and colors of your main and reserve parachutes. Keep the record some place other than your equipment bag. If you have any question regarding the SST, this manual, or the procedures described in the manual, contact:

Jump Shack
1665 N. Lexington Ave. #106
DeLand, Florida 32724 USA
TEL (904) 734-5867
FAX (904) 734-8464

OPERATIONAL LIMITATIONS

TECHNICAL DATA

The SST harness and container system has been certificated in the Standard Category by the Federal Aviation Administration (FAA) under Technical Standard Order (TSO) C-23(b). This TSO refers to National Aircraft Standard (NAS) 804 published in September, 1949. The Tandem is Certified under TSO-C23(c) this TSO refers to AS-8015a published September 30, 1982. To meet these requirements, the manufacturer must submit the design in drawings to the FAA Engineering District Office. The FAA then inspects and certifies the manufacturing facility and approves the quality control of the manufacturing process as described in the manufacturer's manual. The FAA further assures that the manufacturer will trace and inspect each piece of fabric and hardware he uses during the manufacturing process of the equipment.

Under TSO C-23(b), equipment can be tested to Standard Category (sometimes called High Speed) or Low Speed Category. The SST has been tested to the Standard Category which certifies it to a shock load of 5,000 pounds. The rig may be assembled with a Low Speed Category reserve canopy, but then the entire system becomes certificated in the Low Speed Category. (Later installation of a Standard Category canopy restores the system to the Standard Category, of course.) Regulations require the rigger to identify the system as Low Speed Category in the appropriate manner when he installs a reserve from that category. Standard Category requires no markings. Canopies certificated under TSO C-23(c) and later revisions may be assembled into the SST line of containers providing the assembling rigger has complied with FAA regulations and policy. Performance limitations of the installed canopy should be placarded, in the manner required by the TSO document, for the user's information.

The Tandem certified under TSO C23(c) must conform to AS-8015a. The test weight and speed specified in AS-8015a Category B is 300 Lbs. @ 175 KTS.

The Racer Tandem system has been tested to 600 LBS. @ 175 KTS.

Many reserve and main canopies will fit well into your SST, but some won't. Results of packing the wrong-sized canopy into your SST range from difficulty in packing to a likelihood of either a premature pack opening or total pack closure, depending on whether the parachute canopy is too small or too big. FAA Advisory Circular (AC) 105-2, paragraph 5.B(6) states guidelines for component interchange ability, but we've made the decision even easier.

The Parachute Industry Association and the Jump Shack have each published a list of canopy volumes. They tell you the cubic inches required for your container and which size SST you should choose for a specific canopy. If you don't find your canopy listed, call the canopy manufacturer or Jump Shack to find your canopy's volume. Don't guess; it's unnecessary and dangerous.

MODIFYING YOUR SST

Although the Federal Aviation Regulations technically allow alterations to some parts of the assembly by designated personnel, the SST is such an integral system, we don't recommend it. Virtually nothing on the SST works completely independent of the reserve system. We've tested the entire system as a unit, and it should stay that way.

If you think you can improve something, we welcome your comments. It's valuable input from the field that made the SST the great rig it is. We are continually testing new ideas on the SST, and we may have already considered yours. What we have already learned could save you from finding out the hard way.

COMPATIBILITY

Look at the system data information plate under the reserve pin inspection flap to determine the size of the main and reserve containers. Check that information against published Jump Shack canopy volume charts. If there is a problem, give us a call. We make in excess

of 150 different container sizes/combinations on 11 different harness sizes, so there is no reason that your canopies shouldn't fit the containers or the harness not fit your body.

OPERATIONAL CHARACTERISTICS

GENERAL DESCRIPTION

The harness and container are designed and built as an integrated system for reasons of function, safety, and comfort. The components of the harness and container system are made from nylon and polyaramid fabrics manufactured to U.S. military specifications and new (not reconditioned) Mil-Spec. hardware.

The SST, SST/Racer, Racer/Elite™ and SST/TRAINER feature a pre-sized one-piece nylon harness. Every SST employs the Pop-Top reserve container and a one-pin main container. The Tandem is equipped with a drogue stowage compartment which is closed by 1 pin and must be opened before the main container can be opened.

The comfort pads will not absorb water, perspiration, or hold dirt. The padding was chosen for its light weight and durability. Although it won't keep you afloat, it provides some flotation for the system.

Both the main and reserve containers fit snugly around the canopies to keep them in place until the anchored pilot chute extracts them in the proper sequence. This metering effect maximizes the reliability of the canopies by preventing one part of the system from deploying ahead of another which should go first.

The main and reserve containers hinge together for greater comfort. The Pop-Top reserve rides just below the shoulders on the shoulder blades, and the main container rests in the small of the wearer's back. When the wearer moves, so does the SST. This "hugging" ability of the SST keeps the mass of the rig closer to the center of gravity of the wearer, and improves stability and handling. The wedge shape of the whole system improves the aerodynamic profile and facilitates exits from small doors.

THE MAIN SYSTEM

The main parachute canopy may be deployed in any of five ways, depending on the main deployment configuration:

1. Ripcord Deployment

A stainless steel ripcord handle located on the wearer's right front releases a retaining pin when pulled. Pulling this single pin releases a cloth closing loop, and the container opens from the spring tension of the pilot chute. The pilot chute springs from the container into the air stream and initiates the deployment of the main parachute, if proper body position is utilized.

2. Pullout Hand Deployment

A soft handle located on the bottom right corner of the main container connects to a ripcord pin and the base of a springless pilot chute. As the handle is pushed down, the ripcord releases a cloth closing loop allowing the container to open. The pull action then extracts the pilot chute by its base. The wearer must manually throw the pilot chute into the clear airstream to his side and release it. The pilot chute then deploys the main parachute.

3. Throw-out Hand Deployment

A plastic handle at the top of the wearer's right leg strap connects directly to the apex of a limp pilot chute in a leg-strap pouch. The wearer extracts the pilot chute from its pouch and manually launches it into the clear airstream next to him. When the pilot chute has inflated and applied a load to its seven-foot bridle, it extracts a curved pin on the bridle from the cloth closing loop, and opens the container. The pilot chute then continues to deploy the main parachute. This pilot chute may also be stowed and deployed from a Bottom of Container mounted in a Spandex pouch.

4. Automatic Activation

In this configuration, a preset sensing unit determines the altitude and air speed, and activates the ripcord pin (in the ripcord deployment configuration) when the desired descent air speed and altitude coincide. The SST accepts several automatic activation devices (AADs) on the market for use on the main parachute system.

5. Static-line Deployment

Direct Bag:

This is a wearer-passive deployment controlled by a jumpmaster. A static line is attached at one end to the airplane and at the other to a ripcord pin and the main parachute deployment bag. The bag attaches to the top of the main canopy with breakcord. Loading the static line first extracts the main ripcord from the cloth closing loop, then extracts the main parachute bag. When the system fully loads, the breakcord detaches and releases the deployment bag from the canopy.

Pilotchute Assist:

Same as above except that the canopy end of the static line is attached to the main pilot chute with Velcro or Breakcord. Loading the static line first extracts the main ripcord from the cloth closing loop, then extracts the main pilot chute and bag. When the system fully loads, the breakcord or Velcro detaches and releases the pilot chute and bag from the static line. The pilot chute and bag stay with the canopy.

THE RESERVE SYSTEM

The reserve parachute uses the patented Pop-Top pilot chute. It's the only reserve system where the pilot chute is externally mounted—so it doesn't need to push container flaps out of the way to get open—and the ripcord pins are protected between the reserve container and the wearer's back. The Pop-Top system enables the highest launch of the low-volume MA-1 pilot chute spring when the reserve has been properly assembled and packed. **THE SST RESERVE PARACHUTE SYSTEM MUST BE USED WITH AN APPROVED PILOT CHUTE.**

There are three ways to deploy the SST reserve:

1. Ripcord Deployment

The stainless steel trapezoidal ripcord handle is shaped to invite a left-handed thumb hook and thrust type activation while accepting an across the chest right-handed grip and pull type activation. A combination of both or a two-handed activation is recommended. The handle is mounted on the wearer's left main lift web and activates two ripcord pins when pulled. These pins release the two cloth closing loops that route through the pack, over the pilot chute, and back through the pack. Releasing the cloth closing

loop allows the pilot chute to launch into the airstream and deploy the reserve.

2. Reserve Lanyard

This system comes as standard equipment on the SST/Trainer and is used to back-up the above system after the wearer has separated from the main parachute canopy. The reserve ripcord housing is joined by an elastic retainer channel at the front of the shoulder. A cross connector lanyard crosses from its shackle on the right riser, routes under the top section of the reserve ripcord and housing, and then shackles to the left riser. After both of the risers separate from the harness, the lanyard slides along the housing to a dynamic topmost point of suspension. The lanyard extracts the housing from its elastic channel or AAD housing clamp. When all tolerance is taken from the ripcord/housing system, the ripcord pins are extracted, and the lanyard slides free over the remainder of the housing and the ripcord. The spring-loaded pilot chute launches and deploys the reserve canopy.

NOTE: The attachment of a springless pilot chute, w/bridle, to the apex of the main canopy is required to positively assure the activation of the Main/Reserve Interlock. The force required to pull the ripcord is the same as the force required to activate the interlock. Adequate force may not be generated, during a streamer (high speed/low drag) malfunction, when utilizing a direct bag static line system w/o the springless pilot chute.

3. Automatic Activation

When the desired altitude and descent coincide, a pre-set altitude/velocity sensing device fires a pyrotechnic charge into a combustion cylinder and activates a piston. A dog on the piston pushes a tube which slides over the proximal ripcord pin of the reserve ripcord, releasing the cloth closing loops of the reserve pilot chute. The pilot chute then deploys the reserve canopy.

The device described is the SSE Sentinel MK 2000, which has been tested and approved for the SST. The Sentinel MK2000 may deploy the reserve while under a normally functioning ram-air main parachute in a spiral or "riser" turn below 1,000 feet. If your activities include this type of maneuver and you employ a MK2000 it is recommended that you get it "detuned" by the manufacturer. Contact SSE for details.

The FXC Model 12000 can be installed, but only by the Jump Shack as it may require a special ripcord with adjusted pin length to compensate for the reduced pull stroke generated by some Model 12000s. If your rig is equipped with an FXC Model 12000 check the ripcord pin length and advise your vendor upon purchasing a replacement reserve ripcord. **WARNING: If the originally installed FXC 12000 is exchanged, for any reason, the installation should be re-evaluated for function in packed configuration while being worn. This procedure should be performed by the Jump Shack.**

Finally, AADs have both failed to operate when needed and operated before the desired altitude. Whether from fault of the device or user error, AADs should be considered unreliable and used with caution. Nonetheless, Jump Shack strongly recommends the use of an AAD.

AAD SET-UP NOTIFICATION

Your new Racer has been equipped with a kit to accept the installation of a 2-pin CYPRES AAD unit. If or when you decide to have the CYPRES unit installed, the Kevlar quick loop on the reserve pilot chute must be replaced with a quick loop especially made to work with the CYPRES unit. Please ask your rigger or call the Jump Shack for further explanation of the quick loop and CYPRES installation. All rigs built after 1997 are equipped with the Spectra/CYPRES Quick Loop

THE MAIN CANOPY RELEASE SYSTEM

3-Ring Release System—Two rings on the riser acting as force reduction levers retained by a locking loop which serves as a force reduction pulley transmit the load of the opening and suspension to a larger ring on the harness. A handle attached to the main lift web pulls two cables that release the left and right side ring locking loop simultaneously. Simultaneous release was not possible on Racers manufactured before January 1998 and is not possible on any other rig manufactured at this time. After the breakaway, only the large rings remain.

Before using the SST with the above release, consult an appropriately rated instructor.

THE SST TRAINER SYSTEM

The SST/TRAINER meets the needs of modern student training programs. It complies with U.S. Parachute Association doctrines on student training, both for part III, or the accelerated freefall method. The SST/TRAINER readily converts from static line deployment to ripcord deployment to make training easier for the drop zone operator. It is equipped with a “Stevens” main reserve interlock system which causes activation of the reserve container upon separation of both of the main risers. This system is the only one in the industry which employs a full time cross connector on the main risers as standard equipment.

The cross connector/reserve lanyard may be optionally assembled to a single riser. This assembly method is preferred by some operators as it eliminates the cross connector feature. However, this method does make the system sensitive to the connected side. If the connected side of the main releases first a main reserve entanglement could occur, as with other systems.

WHAT YOU SHOULD KNOW ABOUT RESERVE STATIC LINES

The purpose of a Reserve Static Line (RSL) is to provide an automatic link from cutaway of the main canopy to reserve activation. To do this the cutaway canopy must generate a drag force capable of pulling the reserve ripcord.

All means available must be employed to maximize and utilize this drag force. One of the best ways to maximize the drag of a malfunctioned canopy is with a “Cross Connector”.

When the “Stevens” system was first incorporated, tests showed that a canopy with one side cutaway doesn’t always have enough drag to pull the reserve ripcord (22 lbs.+ 5 lbs. for the seal = 27 lbs.). That’s right, you could easily end up with less than a square foot of effective drag surface. Those tests were done using round canopies. There is no reason to believe

that a square canopy would do any better - quite to the contrary.

The original "Stevens System" had the cross connectors at the top of each riser, at the links. That location required two connectors, one front and one rear, to prevent elongation and resultant loss of drag of the main canopy. This configuration is not acceptable on a piggy back as the cross connectors can and do catch under the reserve container. Presently we are enlightened enough to realize that cross connectors placed at the base of the riser near the attachment point to the harness will preclude these problems.

The Racer/Elite™ employs such a cross connector, with "Quick Releases" on both sides. Its routing takes it from the left riser, under the top half of the exposed ripcord housing, over (outside) the top or yoke flap, then to the right riser. The excess lanyard is concealed under the top "lip" of the Pop-Top and the respective sides of the yoke flap. Velcro is provided under the edges of the yoke flap to mate with Velcro on the cross connector itself, thus preventing escape of any critical amount of lanyard in freefall.

After, and only after BOTH risers have separated from the harness does the cross connector load the reserve ripcord pins, pulling them and activating the reserve.

Other solutions to this problem have no cross connector, only a direct link or "static line" to the ripcord pin. We call that type "Side Sensitive"; that is, it activates the reserve when the side to which it is connected has enough drag to release from the harness and pull the pin.

We trouble shoot the mechanics of parachute equipment operation with the "What if scenario". What if... on a side sensitive system, the critical riser releases before the other riser, as they frequently do? The pin is pulled and the reserve pilot chute entangles with the yet unreleased side of the canopy. What if... on a single sided system, the non-RSL side releases and the RSL side hangs up? The canopy "streamers" and fails to generate enough drag to pull the pin. Both of these scenarios have happened with tragic results on single sided systems.

Experience has shown us that all of the single handle cutaway systems in use today release unevenly. Try as we may, we being the designers and manufacturers, no one has developed a reliable method to perform

even release to date. Additionally, prudence tells us that we MUST assume a possibility of a release hang up. As much as 40 pounds of force has been required to release some poorly maintained riser release systems, *after* the cable has been pulled.

The entanglement scenario is prevented with the two pin RSL (one pin to each riser) system. However, it retains the "one side attached without enough drag to pull the pin" problem.

The cross connector system is "what if'ed" with: suppose a previously "totaled" main deploys after the reserve is out. Some say, and we acknowledge, that this rare occurrence would put the reserve over your head with the main inflated and in tow behind the reserve. OK! What if that does happen? We have a good canopy over our heads and plenty of time to disconnect either side of the cross connector thus releasing the main. No panic!

Suppose someone routes the cross connector improperly under the top reserve flap. No one would do that you say! We did it in a test! No problem, we simply pulled the quick release and separation was complete. Later analysis showed that in that situation all one must do is pull the reserve ripcord. Then we not only have adequate separation, but a deploying reserve as well. Additionally, an AAD would provide the ripcord pulling chore.

Cross connectors have been faulted with snagging on Bell helmets (which were not designed with skydiving in mind). This, by the way, never prevented the RSL from doing its job. We submit that it is the fault of the helmet design and not the RSL. Helmets and all other pieces of extraneous parachute equipment shouldn't have edges that snag.

On the Racer/Elite™ the choice is yours: single sided, cross connected, or none. If you decide to do CRW on the way down and want to disconnect your RSL, simply release either one of the snap shackles and go for it! The Racer/Elite™ RSL, with its unparalleled 20 year safety recordbecause it works better.

The Drogue System

The Racer drogue which is used on both the Tandem and the Tactical Racers is unique to the parachute industry. It is a back center mounted fall rate reduction and stabilization device which is anchored to the front

of the jumper and is releasable at the rear of the jumper. Releasing the drogue deploys the main canopy. In the case of the presents of a passenger or bundle, or both, it is anchored to the center of the most forward load. The drogue suspension system has it's own compartment located between the main and the reserve. It has its own closure flap (see Second Level Closing). The drogue canopy is stowed in a spandex pouch at the bottom of the main container. It is right hand operated and deployed like a **Throw out Hand Deployment** pilot chute The drogue bridle is releasable via a 3-Ring release system located at the base of the bridle. The bridle is equipped with a large ring which serves as the base ring which is the "flyaway" end of the release. A back center mounted drogue riser, which is part of the front mounting system, is equipped with the releasing rings and cables. There are three distinctive release points on this riser. The three releases are intended for the master, the passenger and the cutaway riser release. This means that when you cutaway the main canopy the drogue also releases. This additional safety feature means that your emergency procedures are the same for drogue assisted fall and non-drogue assisted fall. The Racer Drogue is small and light weight and easy to deploy yet it produces a fall rate equal to a solo fall rate. We have measured the fall rate of a 400 LB tandem load

both with the drogue and without. Without the drogue the fall rate is 143.7MPH @ 9000ft.. With the drogue out at 6000 ft. the fall rate was 117.3 MPH. These are average speeds taken over the previous 1000ft. After falling for 2000 ft. which allow for stabilization. Some Drogues are collapsible. That is they are collapsed after the canopy is extracted from the bag so as to not continue to drag during canopy flight. This is accomplished via a "Kill Line", routed through a channel in the bridle from the bag to the apex of the drogue canopy, which pulls, that apex, to the bridle attachment location of the canopy thus inverting the canopy reducing the effectiveness of the drogue. If this "Kill Line" is not reset during packing the drogue will not be inflated during deployment. This has happened. The fall rate of the tandem pair was excessive (140 to 145 MPH) the opening force was subsequently higher, however, the system has never failed to operate under these conditions. Most importantly, the excess "kill line" should be pulled up into the canopy when it is set. This allows the slack in the "kill line" to be available during bridle stretch and loading. Failure to not do this will result in excessive "kill line" wear.

INSPECTION INSTRUCTIONS

CYCLIC INSPECTIONS

The Federal Aviation Administration requires that all parachute systems in use for emergency circumstances be inspected every 120 days. This inspection process is well known and generally thought of as a canopy inspection only. Such is not the case. The harness and container and its accessories, such as the pilot chutes, bridles, bags, and cables, must be thoroughly examined and certified as airworthy at the same time. You, as the user of this equipment, should be familiar with and check these items more frequently such as every time you pack or jump it.

All SSTs should be inspected for: Broken or frayed fibers on webbing, cables, container fabric, tapes, locking loops, and housings; broken tacking; severe discoloration or fading (and indication of possible sun light damage); grommet distortion; bent ripcord pins; worn velcro; broken stiffeners; broken stitching; and a general look at the overall appearance.

PRE-JUMP INSPECTION

The “jumpmaster check” should be performed before every jump by another person who is familiar with the equipment you are using. It should be performed in the following manner. “Hands on”, beginning at the front of the wearer at the leg straps and proceed up the front of the wearer to the shoulders then to the rear of the wearer at the top of the shoulders and down to the bottom of the rig. Observe for: properly threaded and routed leg straps, properly threaded and routed main lift webs, securely seated ripcord and cutaway handles, properly threaded and routed chest strap, proper and secure assembly of the riser releases, proper routing of the risers, proper seating of the reserve pilot chute, proper seating of the main ripcord pin, proper routing of the throw-out bridle if so equipped, proper routing of the pull out lanyard if so equipped, housing to cable clearance of the main ripcord cable if so equipped, and back to the leg straps for assurance of proper routing.

MAINTENANCE/REPAIR

PERSONNEL QUALIFICATIONS

The FAA states that minor repairs may be done by a Senior Rigger and major repairs must be done by a Master Rigger. They further define minor repairs as anything that does not affect the airworthiness of the equipment, and major repairs as anything that does affect the airworthiness. This regulation/policy is subjective and open to discussion. You as the owner and your rigger should discuss the required repair and make the best decision you can. If there is still some question call us.

MAINTENANCE PROCEDURES

Your new rig is designed so as not to require any routine maintenance except for the 3-Ring system. It must be disconnected and the following procedure performed as indicated.

1. With a nylon brush remove the cadmium oxide deposits on the webbing where it contacts the rings. At the same time, flex the webbing assuring that it is soft and supple. This step may be performed during the Inspection cycle.
2. If your Racer is equipped with a yellow cutaway cable you should with "3 in 1" oil or equivalent wipe a light coat onto the release cable. This process should result in a clean well oiled cable. **This should be done weekly!** If your Racer is equipped with a red Teflon coated cable it is not necessary to lubricate it.

MAIN CLOSING LOOP REPLACEMENT & ADJUSTMENT

The main closing loop is constructed of Type 5 Nylon Cord Sheathing. The running end is finger trapped back into itself at about one (1") inch past the center. The finger trap is drawn out of the end of itself and the

ends are drawn even. By selecting the Type 5 sheathing we avoid the requirement of a washer to retain the knot behind the grommet.

The location of the knot, and ultimately the length of the "Thru Loop", is determined by trial and error. With the loop adequately long to allow for a first time closing, close the main and pin the loop leaving the pull-up cord in place. Now take a grip on the pull up cord and pull it with one hand while the other hand presses down on the top main flap. Determine the amount of loop exposed between the pull-up cord and the grommet, then release the pull-up cord. Open the top flap and unthread the pull-up cord from it. In order to access the knot of the "Thru Loop", saddle bag the rig as described in the section of the owners manual about Closing the Main. Leave the pull-up cord in place through the grommets of the side and bottom flaps. Pull the cut end of the "Thru Loop" away from the retaining grommet exposing the knot. Relocate the knot the same distance determined above. Close the container and repeat as necessary.

Note: Loops which are too long can increase the frequency of accidental activation of the main, and loops which are too short can cause hard pulls. Both cases should be avoided.

REPAIR PROCEDURES

The best guide for the execution of general repairs to be performed on parachutes is "The Parachute Manual" by Poynter.

Tacking, the most commonly required repair on any rig should be replaced with waxed nylon 5 cord in the same manner as originally manufactured with one exception. That is, the comfort pads on Racers were originally tacked to the main lift web just above the chest strap in two places with two turns of waxed nylon 5 cord. This tack breaks occasionally and should be replaced so that the bottom edge of the comfort pad lines up edge to edge with the top of the chest strap. As an alternative it may be sewn with a machine. The machine stitch should traverse across the main lift web

on the binding tape of the comfort just above the chest strap.

Velcro pile should be replaced as required using a Fed. Std. 751 Type 301 stitch with a 2 inch over stitch.

Velcro Hook should be cleaned and only replaced if necessary. Use “Type B” hook. Attach in the same manner as the pile.

Stain removal should be performed with a non-detergent soap with a dry suds and a light nylon brush.

A non-volatile, non-corrosive dry cleaning solvent also works well. We use “Picrin”.

Any broken or frayed fibers should be replaced, distorted grommets should be reformed or replaced, discolored or faded fabric should be tested and replaced if necessary, bent ripcord pins straightened or replaced, broken stiffeners replaced, and broken stitches replaced.

ASSEMBLY

PERSONNEL QUALIFICATIONS

Only a currently FAA licensed rigger may assemble, inspect, pack, and certify the reserve of an SST as air-worthy. Riggers are required to have *this* manual available to them while servicing this system. They may be certificated for chest or back reserve to pack the SST. They may record the pack job in their log as either chest or back type. Per the FAA regulations you must be familiar with any type of reserve parachute you wish to certify. We believe that a ram-air rigger rating, formally issued to FAA riggers by the U.S. Parachute Association to pack a ram-air reserve, provides this type of familiarity. Failing this you must have received some sort of formal training to qualify for packing ram-air reserves into an SST type container.

The main canopy and its accessories may be assembled and packed by you or a licensed rigger.

PARTS LIST

The harness and container
Main pilot chute
Main deployment bag
Main risers
2 Sets of Toggles
3-Ring Release
Reserve ripcord
Reserve pilot chute hat
Quick Loop
Pull-up cord (inside main flap)
Reserve Packing data card
2 Main cloth closing loops
Reserve pilot chute and bridle
OPTIONS:
Reserve free-bag (ram-air reserve)
Cross Connector/Reserve Lanyard
AAD
Main ripcord
Spring loaded main pilot chute

RESERVE ASSEMBLY

A. Connect the canopy to the reserve risers. When assembling a new SST, you have the choice of using L-bar or Rapide links. The risers come from Jump Shack ready to accept Rapide type links.

The PIA (Parachute Industry Assoc.) urges riggers to install round canopies on four risers to help the performance of the canopy. Pioneer requires that if their K-series reserves are installed on four risers, then #6 Mallion Rapide links must be used. To install L-Bar links on Racer reserve risers carefully add type 8 or 12 buffer webbing between the link and the riser webbing.

For Rapide links, turn under the edge of the riser webbing to buffer itself and install the links. Turn the barrel nuts until snug plus one-quarter turn.

B. Insert the running end of the steering line down through the guide ring mounted on the riser and then through the grommet of the steering toggle entering from the velcro side. Wrap the line around the toggle 360 degrees from where it exited, passing above the line that enters the grommet. Then, insert the running end back through the grommet exiting on the velcro side. The end should exit the grommet above that portion of the line which wraps around the toggle. Tie the running end and the main steering line together straddling that portion which is wrapped around the toggle, using a half-hitch and locking knot. Finger trap and tack with 5 cord nylon waxed.

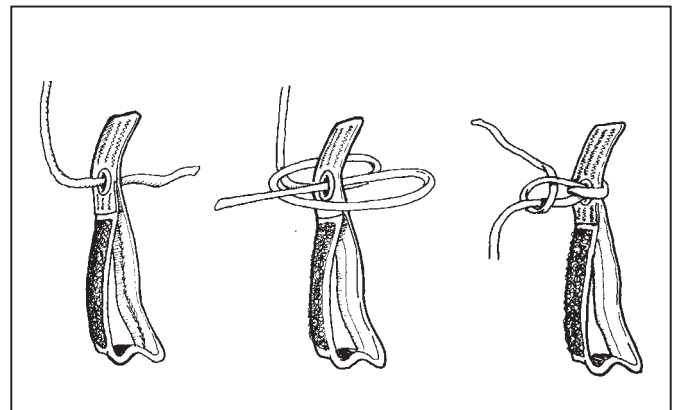

C. On round canopies, thread the bridle through the radial tapes at the base of the pilot chute, then thread the other end through the loop provided in the bridle and pull it tight. Route the other end of the bridle through the apex vent lines, making sure to catch all of them, then bring the loop over the top of the pilot chute and back down to the apex. Secure the bridle loop to itself with one turn doubled of waxed nylon 5-cord, so it slides freely on the apex. THE BRIDLE MUST NOT RESTRICT OR CHOKE THE APEX. IT MUST SLIDE FREELY SO AS TO ALLOW SELF CENTERING.

On Square canopies only the pilot chute to bridle need be assembled. The procedure is the same as for round canopies.

TANDEM CANOPY ASSEMBLY

All Tandem canopies should have a rubber stow band attached to the line attachment point of one of the in-board "B" lines. The center of the slider should be stowed in this retainer during packing. The purpose of this retainer is to prevent the slider from coming down the lines prematurely. It is a good idea to do this to any canopy.

SST/TRAINER ASSEMBLY

Install the reserve static line system at this time.

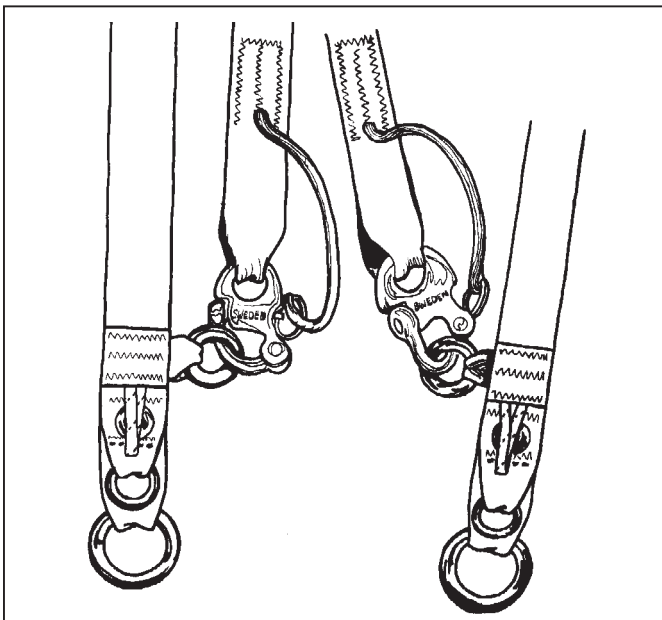

Note: To preclude the possibility of inadvertently routing the static line under the top reserve flap we recommend that the reserve be packed and sealed before taking the following steps.

A. Pass one end under the top half of the reserve ripcord housing, BUT NOT UNDER THE RESERVE RISERS OR THE TOP FLAP OF THE RESERVE CONTAINER.

B. Connect the shackle to the small ring located on the side of the riser.

C. Repeat for the other side.

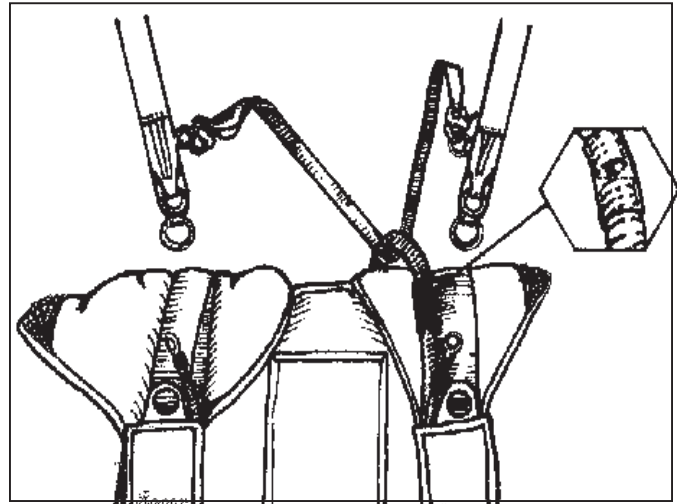

D. Stow the reserve static line in the channel over the wearer's shoulder and mate the velcro on the yoke or top flap.

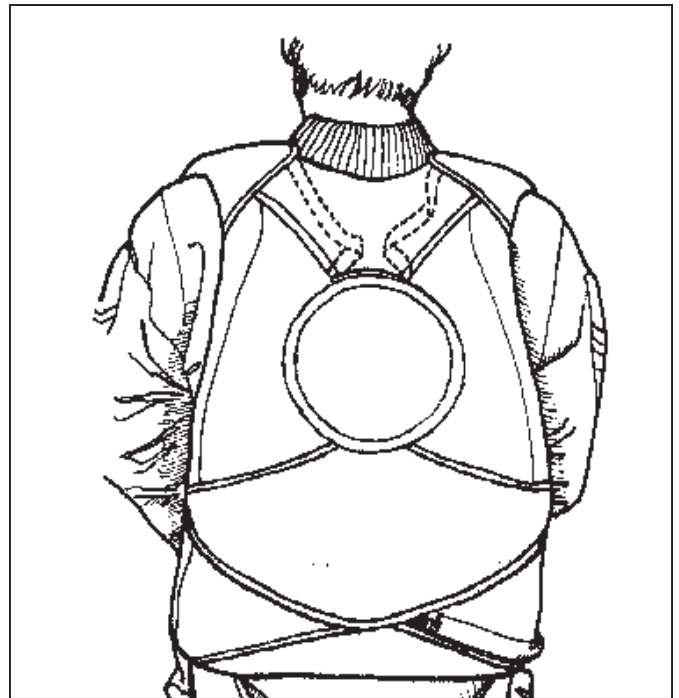

INSTRUCTION FOR CHANGING FROM STATIC LINE TO PILOT CHUTE WITHOUT UNPACKING THE BAG.

E. Attach the loop of 9/16 tubular provided to the apex of a round canopy or the bridle attachment point of a square canopy by looping it through and tacking the loop, with one turn of waxed nylon 5 cord doubled, so that it does not choke the vent lines on a round canopy. Local manufacture of this item can be accomplished by making a loop, on the vent lines, which has strength equal to the strength of a pilot chute bridle and length adequate to pass through the bag grommet to the break cord tie location on the trainer bag, about 12" circumference.

NOTE: This loop must float on the vent lines.

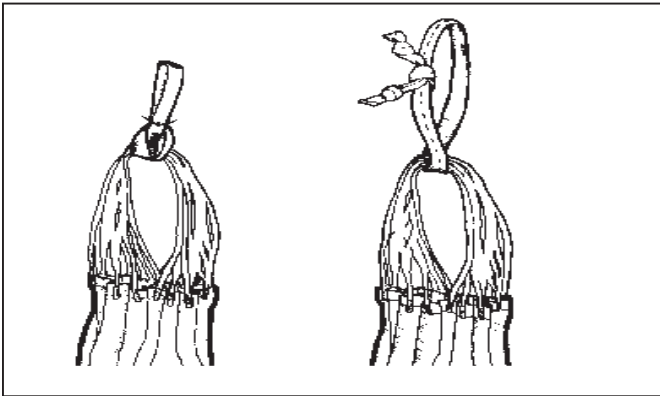

MAIN ASSEMBLY

1. Install the elastic stow bands on the deployment bag. For most canopies you will need one elastic band for each locking stow and from two to four on each side of the bag. **NOTE: DUE TO THE VARIETY OF LINE DIAMETERS AND SUBSEQUENT STOW BULK, ELASTIC STOW BANDS ARE NO LONGER SUPPLIED BY CONTAINER MANUFACTURERS. THEY SHOULD BE SUPPLIED WITH YOUR CANOPY.**

2. Thread the main pilot chute bridle through the grommet at the top center of the bag with the stow bands on the outside. The mouth of the bag faces away from the pilot chute.

3. Thread the bridle through the bridle attachment point on the top of the square parachute (or through the apex lines of a round parachute), then back through the grommet and over the pilot chute from the top. When you finish, the pilot chute bridle loop will have returned once more through the grommet and be tightly secured around the canopy's load-bearing point (or apex loop).

4. Lay the container face-down on a packing mat with the packed reserve container toward the main canopy. Attach the risers to the container by looping the bottom riser ring through the main harness ring and then the small riser ring through it, bringing the cloth locking loop over and through the small ring and then through the grommet in the riser. The loop is then routed through the terminal eyelet in the adjacent housing whereby the release lanyard is then threaded through the loop. No less than 6 inches of cable should extend beyond the loop and eyelet. This excess cable is then stowed in the cloth channel provided in the back of the riser.

5. Install the canopy on the risers making sure nothing is twisted and the line rotation is correct. If you don't completely understand how to do this, consult a rigger. Don't guess, or you may find yourself under a canopy going backwards or worse!

The Type VIII & XIII risers have been designed to accept connector links similar to the #6 Mallion Rapide link. If you wish to install your canopy on the older type L-bar links, add a buffer and sew it in with a U shaped pattern against the link channel to prevent the link from twisting while it's loading. The newer Type 17, 1" risers accept the #3.5 Rapide link, but not the L-bar type.

6. Install the steering toggles at this time (See RESERVE ASSEMBLY Paragraph B). Consult your Canopy owners manual for proper location and subsequent adjustment.

7. Insert a closing loop into the retainer provided in the main container tray next to the bottom center of the reserve partition (if one is not already installed from the factory).

NOTE: WHEN REPLACING THE MAIN LOOPS DO SO WITH GUTTED TYPE 5 NYLON CORD, OR THE EQUIVALENT.

RESERVE PACKING INSTRUCTIONS

GENERAL

There are many types of reserves on the market, and the SST will accept most of them. Jump Shack has developed specific packing instructions for each type. It's the rigger's responsibility to use the appropriate method for any reserve he packs, and to pack according to the harness and container manufacturer's instructions if there is a difference in the methods described by the canopy manufacturer's instructions.

CRITICAL POINTS

Compatibility—Make sure the canopy you're packing is the right size for the SST it's connected to. Even if it was in there before, someone else's mistake will become yours when you sign the packing data card.

Closing loop length—A too-short closing loop results in a dangerously hard pull. One that's too long makes the pilot chute hat look messy and can snag protrusions on the airplane.

Pilot chute closing loop assembly—You must use the specified materials to assemble the pilot chute, closing loop, and hat. Total malfunctions of the reserve could result from the wrong tacking cords.

Clear channel for the loops—Visually inspect the completed pack job from the back and the front (backpad) of the container. Make sure that no lines, canopy, or pilot chute material can hinder the closing loops' passage through the container.

REQUIRED TOOLS

This Manual

Line Separator (Round Reserve Only)

Tension Devise (Round Reserve Only)

(3) Shot bags

(2) SST Bodkins, Jump Shack Part Number 2003

(2) Full gutted 550# (type III) pull-up cords 36" long

Packing paddle or fid

Ruler or template for marking pilot chute

A pen or soft lead pencil for marking

Large sewing needle (for tacking)

5 cord nylon waxed for tacking

PART ONE: PREPARATION

1. Count your tools.
2. Inspect the canopy according to the manufacturer's instructions.
3. Read instructions and review.

PILOT CHUTE, CLOSING LOOP (QUICK LOOP) & HAT

A. While seated, place the pilot chute between your legs with the top facing up. Rotate the swage to the eleven o'clock position.

B. Lay one end of the Type 4 (square weave) tape over the edge of the pilot chute, **loop side up**, at the twelve o'clock position. An equal amount of tape should hang over the edge at the six o'clock position.

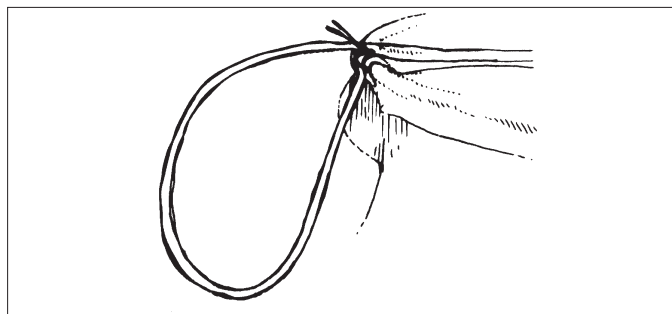

C. Whip stitch each end of the Type 4 to the pilot chute spring across the width of the tape and back. The stitches should pass through the tape from the underside of the cap, through the parapack fabric of the pilot chute cap, around the spring, and through the parapack pilot chute fabric and tape at the top. Care should be taken not to catch any pilot chute canopy fabric in these stitches. Tack the parapack around the spring with each whip stitch.

Also remember, if you sew through the Kevlar loop, the running end must still be able to slide freely in the finger trap. Sew only through the standing end.

D. Center the loop across the top of the cap by placing a ruler across the cap at the ten and two o'clock position, perpendicular to the loop. The loop must be centered exactly, or the pilot chute will "tip over" after the finished pack job has settled. Experience has taught us to use a ruler or better still, prepare a template made

from poster board. It should be 6 inches in diameter with notches at the 12 and 6 o'clock position for marking the location of the loop on the top of the pilot chute.

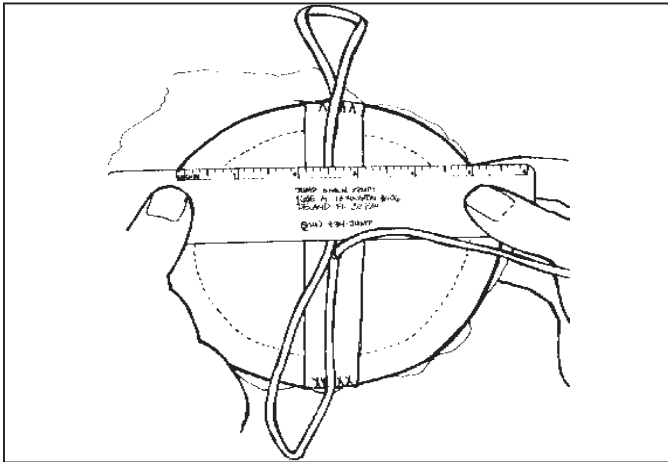

Take a moment to evaluate the operation of the quick loop. Each knotted free end adjusts the length of the loop on the opposite end.

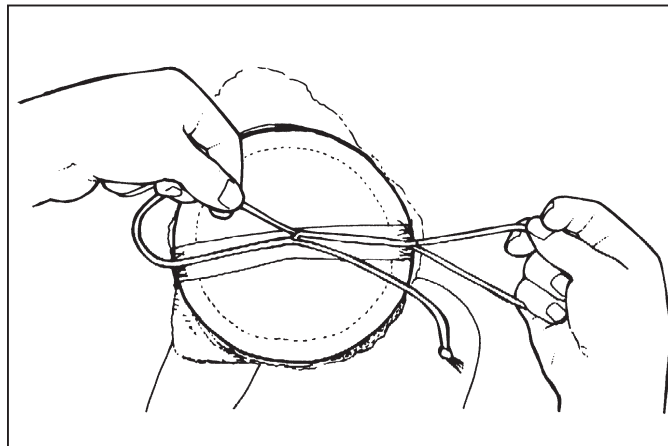

After the first closing of the reserve container, the running ends are pulled until the pilot chute seats snugly into a depression on the back of the container.

You may then wish to tack the finished loop together to within one-quarter inch of each end. Refer to "TACKING QUICK LOOP" under "PART THREE: CLOSING CONTAINER" in this chapter. These procedures assure that every SST has the right loop length for a good pack job and an easy ripcord pull. The Kevlar loop doesn't stretch and allows the ripcord to slide more easily than a nylon one, even when the pilot chute is pulled firmly down onto the container.

E. Lay the hat on the top of the pilot chute, and thread the closing loops through the small holes provided in

the Type 4 valance. Each free end determines the length of the loop on the opposite side of the hat.

F. Tack the pilot chute hat with waxed nylon 5-cord in no less than the eight points shown as follows:

Fold the parapack pilot chute top over the spring. Insert the needle through the folded over edge, around the spring, through the top of the cap and the Type 4 lip very close to where it joins the binding tape of the hat. Return through the Type 4 lip near where the tacking exited and tie the two ends using a surgeon's and locking knot.

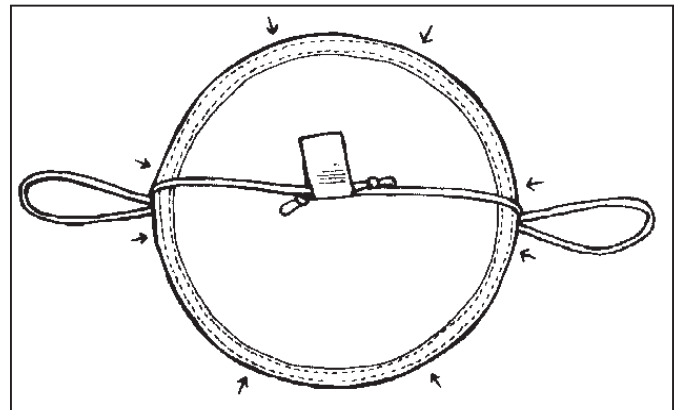

G. Temporarily tie or tape the running ends of the quick loop together over the top of the hat to keep them out of the way while closing the container.

4. For all but Type V canopies layout, inspect, record, flake, and fold the reserve canopy according to the manufacturer's instructions.

5. For all but bagged canopies insert the bodkins up through the two grommets in the ripcord stiffener plate.

PART TWO: PACKING

NOTE: Several industry studies have shown that deployment diapers increase reliability and reduce damage to round reserves. Jump Shack recommends the use of a FULL diaper on round parachute canopies and no longer provides facility for packing round canopies without full diapers.

There are essentially five methods for packing/deploying reserve canopies; they are:

TYPE I: Canopy-first deployment no diaper or deployment device. All lines stow in the container. Examples: 24' T-10A, Navy Conical, early Security,

Strong, and Pioneer Lapos. No longer supported by current production. Available by special request only.

TYPE II: Two-bight diaper. Two locking stows from one-half of the lines secure a wrap around the skirt of the canopy until full line stretch is achieved. The rest of the lines stow in the container.

Examples: Strong and Security Lapos, Steinthal Nimbus, Pioneer K- series, early G.Q. Security SAC. No longer supported by current production. Available by special request only.

TYPE III: (Piglet/Phantom) diaper. All lines stow perpendicular to the radial seams at the bottom of the canopy. Sometimes an extra fold of canopy also goes into the diaper.

Examples: Featherlite, Piglet, Phantom.

TYPE IV: Handbury diaper. All lines stow parallel to the radial seams. Generally, three full stows of lines secure a wrap around the skirt.

Examples: Later SAC, later Strong 26' and Lopo Light and Preserve. Hobbit ram-air or any ram-air converted under AC 105-2 Par. 5.B(6).

TYPE V: Free Bag Ram Air. Canopy packed into a untethered deployment bag with lines stowed in or on the bag.

Examples: Swift, Raven, Firelite.

RISER PLACEMENT

Lay the reserve risers flat along the harness as it passes over the shoulder then follow the side walls of the container down to the bottom corners then fold along the 90 degree bend and follow the vertical partition. Tacking is not necessary for systems with long risers.

PACKING TYPE I & II

Jump Shack recommends that any reserve which would normally fall into the Type I or Type II category be modified to a Type III or Type IV full diaper configuration. AC 105-2b Par. 5.B(6) provides authority for such modification.

PACKING TYPE III

1. Stow the lines on the diaper according to the canopy manufacturer's instructions.

2. Place the diaper in the bottom left corner of the container just as it lay on the packing table. You may fold the lines near the center over onto the other lines (Taco Fold) to make the bundle as wide as the left side of the container.



3. Fold the canopy back over the top of the diaper and across the bottom of the container to the other side. Fill the left-side corner before you cross over.



A great amount of canopy can be stowed in the bottom center area below the pilot chute. If it is properly filled it will relieve stress lines and depression after closing.

4. Fold the remainder of the canopy in the right side of the container. Starting with a long fold and stowing progressively shorter folds each time forms the wedge shape of the container without bumps. Keep the canopy fabric at least one inch away from the top of the container or it will work out before the next repack.

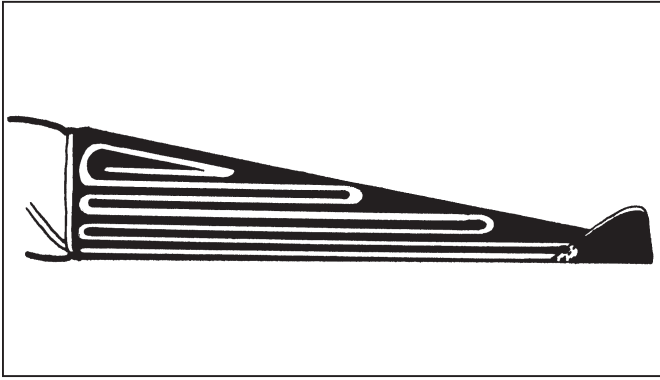

Note: The diaper may be flipped placing the skirt at the top of the container and the lines down to accommodate different size canopies/containers. The important thing is that no twists be placed in the canopy during container installation.

MOVE TO PART THREE!

PACKING TYPE IV

1. Stow the lines in the diaper according to the canopy manufacturer's instructions.
2. You may lay the diaper in horizontally across the bottom of the container and make a 90 degree fold toward the top of the container.

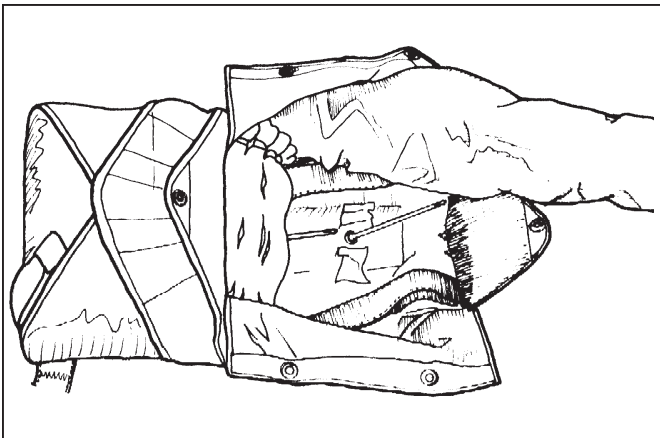

Then you may make a series of stack folds with decreasing length to follow the taper of the container. At a point about two thirds to the apex make another 90 degree fold back across the container between the bodkins and another 90 degree fold to vertical and finish with decreasing length stack folds. Or you may stow the remainder of the canopy by "S" folding back and forth from right to left.

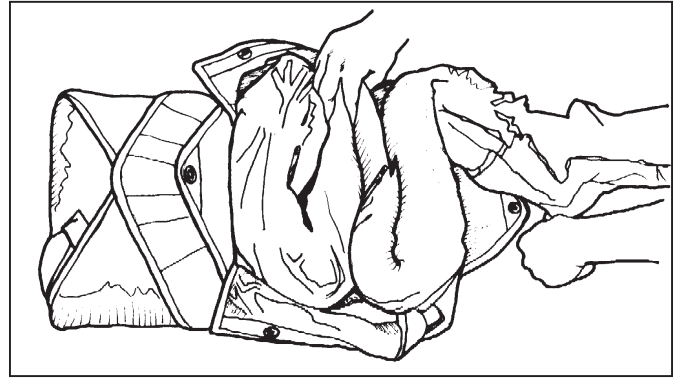

You may also lay the diaper in vertically on the left side and continue packing as in TYPE III.

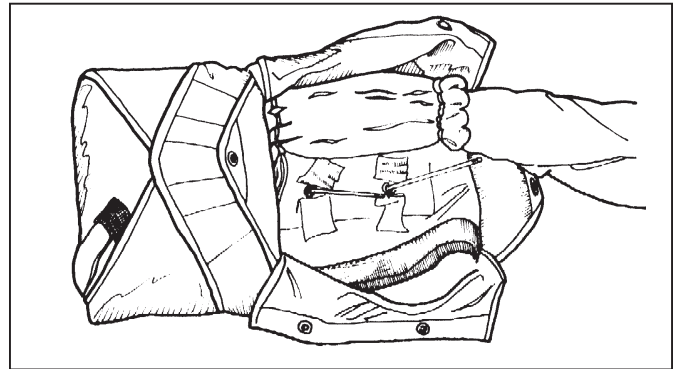

NOTE: The Hobbit ram-air reserve with the TYPE IV diaper has been tested and approved for this method. The diaper may also be placed vertically and packed like TYPE III. Setting the brakes as described in Type V is required for this option.

MOVE TO PART THREE!

PACKING TYPE V

(Except Diapered Ram-Airs, see Type IV)

Assemble, inspect, and check line rotation according to the manufacturer's instructions and Chapter 9.3 of the Parachute Manual by Dan Poynter. The method described in the following passage does not preclude the use of the method described in earlier editions of the SST Owners Manual.

SETTING BRAKES:

- A. Pull the steering line through the guide ring mounted on the riser down to the eyelet provided in the steering line.
- B. Fold the excess in half and insert through slot in top of riser.
- C. Place the loop made by the excess over and in line with the brake eyelet.
- D. Insert the toggle through the loop in "C." and then through the brake eyelet.

E. Insert the toggle into it's elastic keeper and seat it to the mating velcro on the riser.

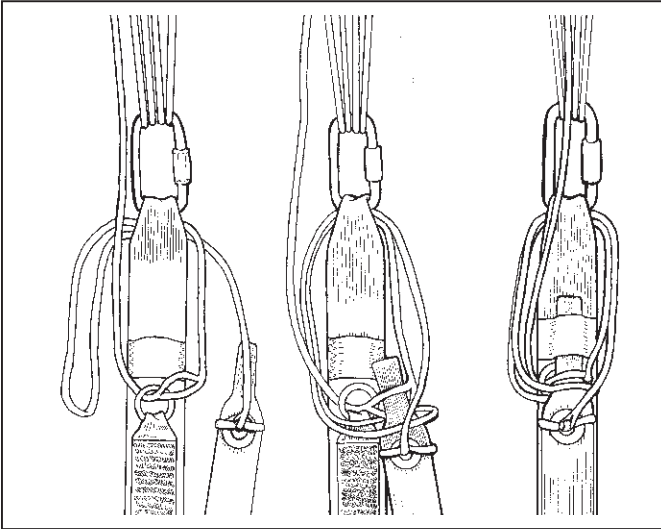

FOLDING CANOPY:

A. Set the bag near the top of the canopy with one T-handle through the bottom grommet and one through the left end of the safety stow.

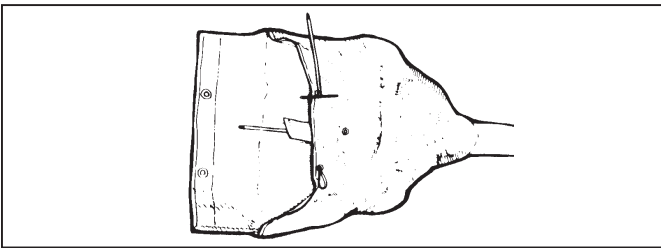

B. Separate the four line groups below the slider and walk the slider up toward the canopy while lifting the canopy off the floor. Seat the slider grommets against the slider stops.

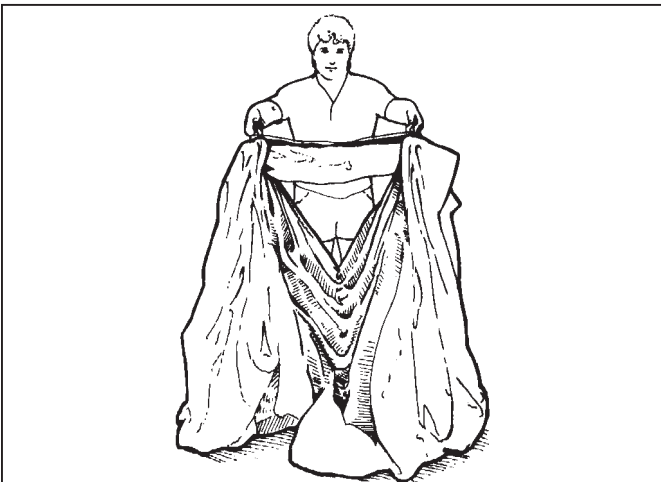

C. Hold all the lines in one hand while standing, and organize the nose. It should now face the container.

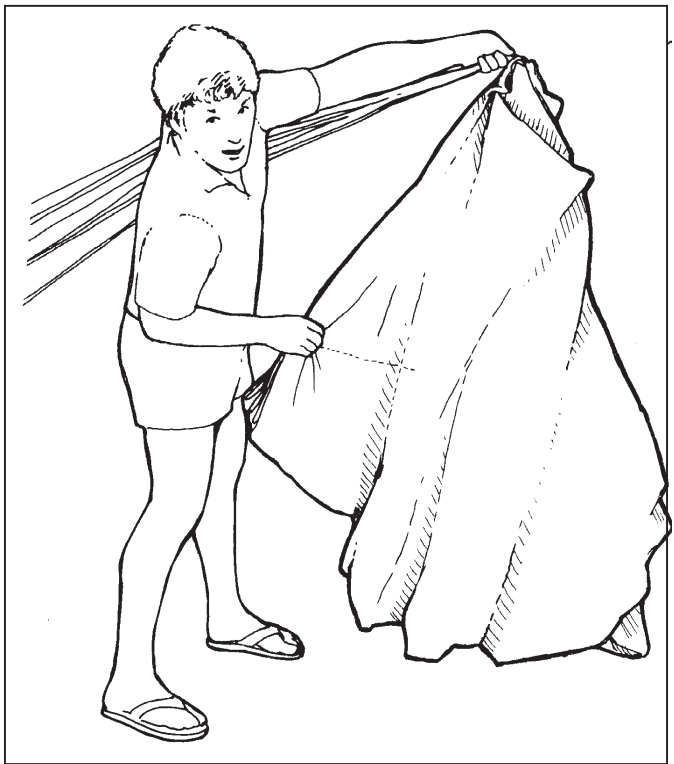

With “HANDS ON” trace and clear the perimeter of the canopy pulling all stabilizers toward the outside of the bundle.

NOTE: This process is similar to the flaking of a round canopy and must be done with care as panels not cleared could cause a malfunction.

D. Place the center tab of the tail under your thumb as shown



E. Sweep your forearm under the nose of the canopy and lay it on the floor. The bundle will spread out widely, but neatly.



F. Kneel at the top of the canopy facing the container. Draw the canopy toward you while at the same time narrowing the bundle to the width of the bag. Constantly work the fabric away from the links.

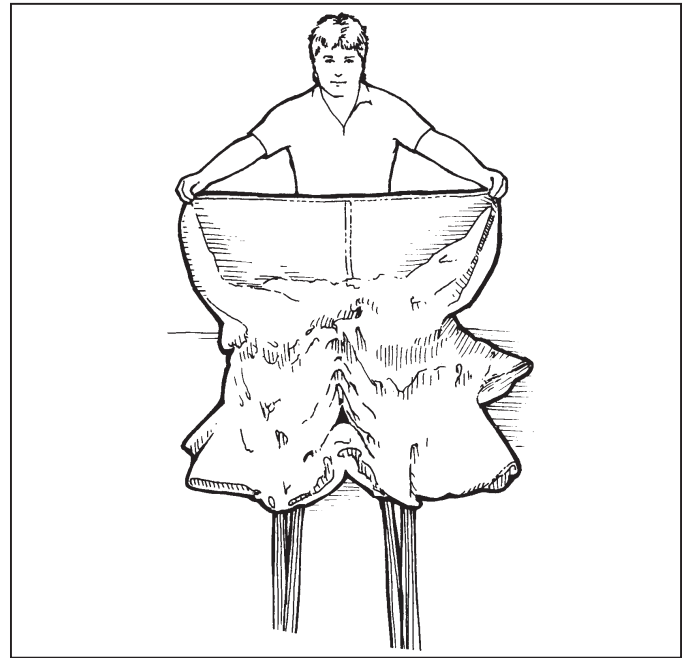

H. Fold one-half of the tail over the bundle to inspect the stabilizer folds. Dress the tail, stacking all chord seams neatly over the center line (air channel) and neatly lay all stabilizer and tail fabric to the outside. Repeat with other half of tail back to the center. Stow the slider in its rubber band.



G. Pull the center tab of the tail to the top exposing the air channel.



I. Return the center tail tab to the bottom center of the bundle. Where the stabilizers attach to the main body of the canopy. “Cocoon” the canopy to the width of the bag.

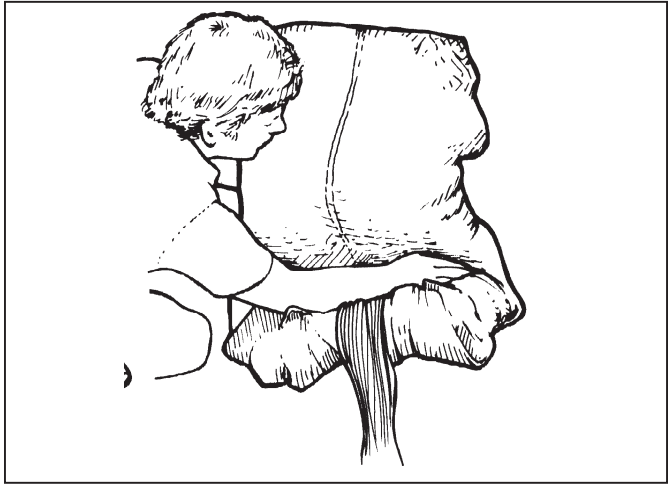
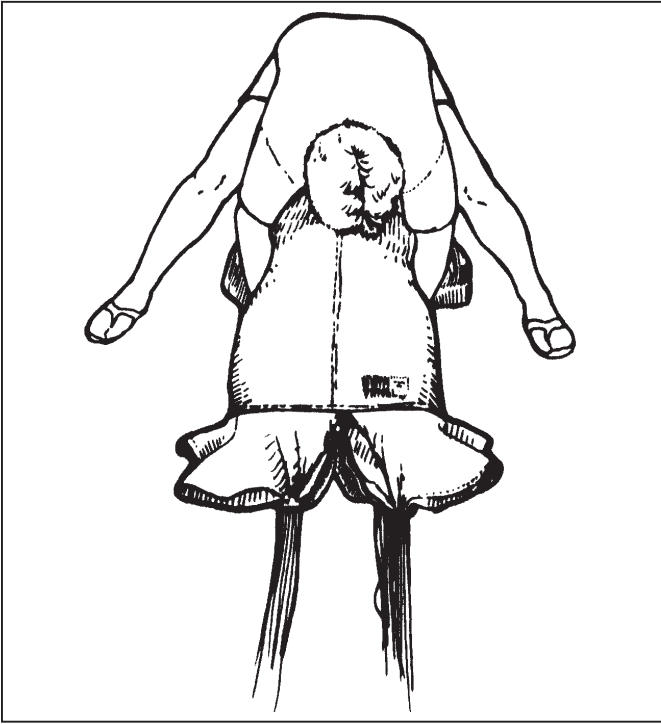

K. Fold each section of the nose outward from the center so it takes air quickly during deployment.

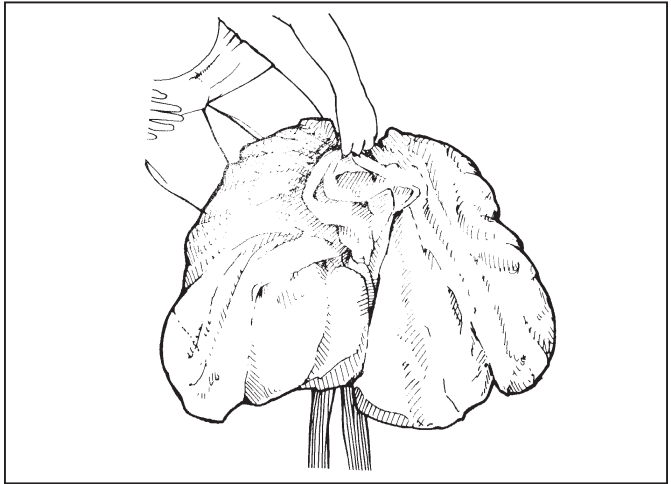

L. Fold the canopy back over so you now have an 8" S-fold at the bottom.

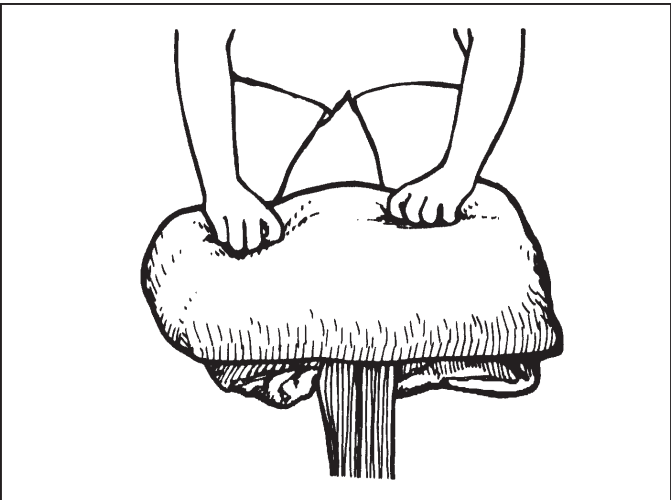
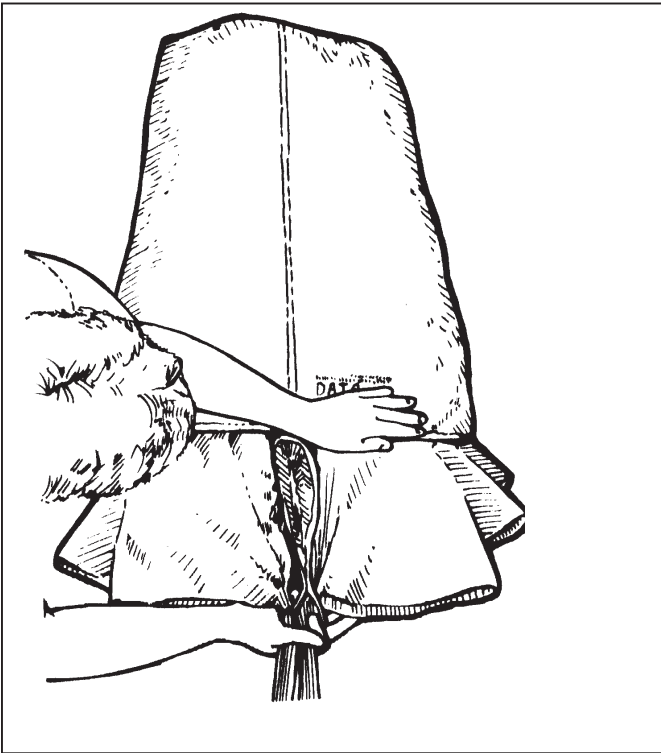

M. Tuck the remainder of the canopy under the bundle until it is the height of the bag.

NOTE: Care must be taken during the cocooning process so as not to disturb the air channel and lines of the canopy.

J. Fold the exposed stabilizers back under the tail.

Lay your hand 6"-8" from the bottom of the bundle and fold the canopy back over itself.

PLACING CANOPY INTO BAG:

A. Face away from the container and kneel on the packed canopy to keep it under control. Shape the bundle to resemble the bag, prepare the bag and install the canopy into it. The T-handle bodkin should protrude from the bottom at the center, however, all of the canopy may be placed *below* the “T” handle bodkin on certain sizes of containers.

Discussion: *The SST line of reserve containers are available with three different distances between the bottom grommet and the vertical partition. Obviously, on containers with only 1 inch available in this area, it is required to place the center cell of the canopy, as above, under the pilot chute. On containers with 2 or 3 inches available in this area the rigger has the option, depending upon canopy bulk, to place the center cell of the canopy above or below the bottom grommet. The decision, on this choice, is made based upon appearance as function is not affected.*

B. Make sure the buffer tabs are between the bodkin and the canopy fabric. Bring the bodkin between the right and left line groups. Form a V-shaped dent in the bottom of the bundle with the bodkin and thread it through the grommet on the top. Clear the buffer tab again.

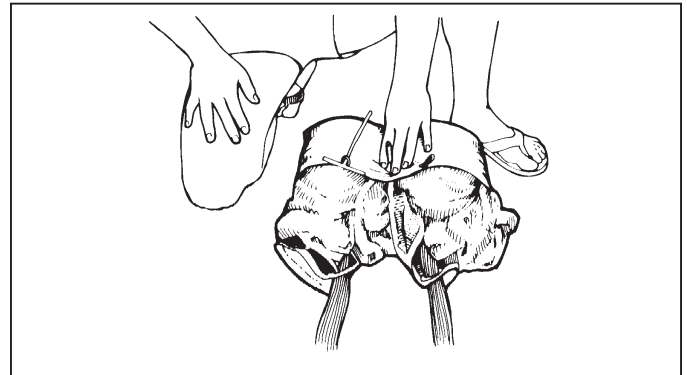
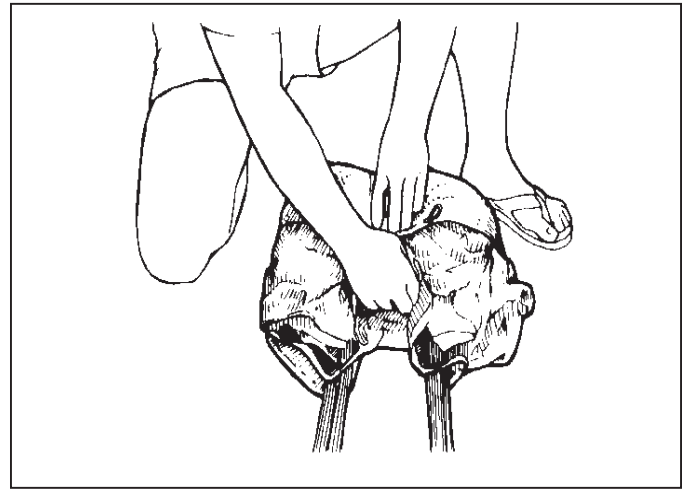
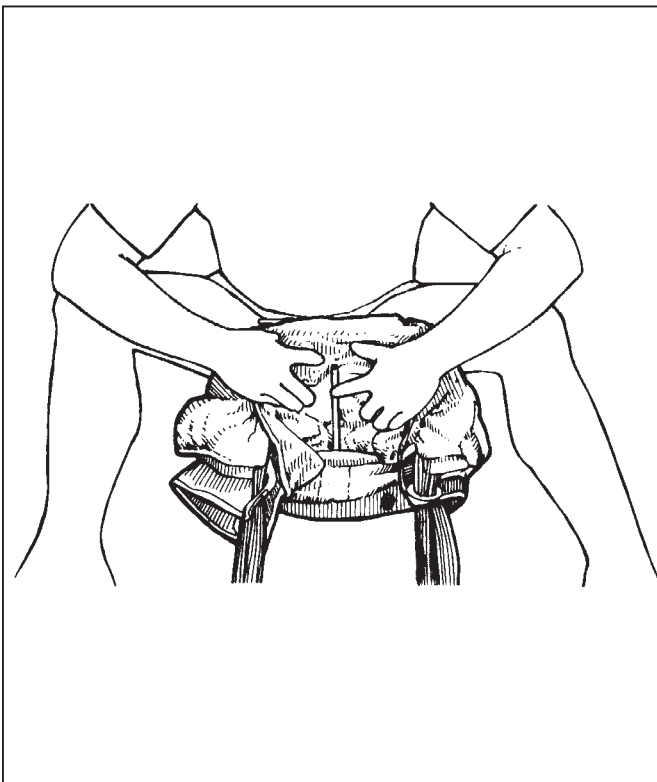

C. Close the bottom flap of the bag by threading one of the locking loops of the safety stow through the mating grommet and place the line bight of 1.5 to 2.5 inches through the stow loop. Repeat for the other side. **TIP:** *The second bodkin will keep the safety stow from pulling through while making the first locking stow.*

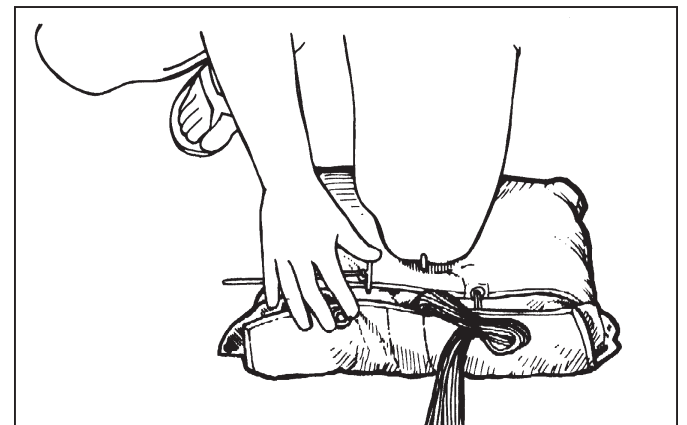

Note: *The safety stow loops must, in a firm manner, retain the locking bights of the bag while it is lifting off the jumper's back during deployment. It comes in a fixed length while the space between its grommets may vary depending upon the tension generated by the enclosed canopy. This alone can allow the reten-*

tion of the bight in the stow loop to vary. Now comes the different line diameter from different canopy manufacturers and their associated bight bulk as an additional variable. Combined they could allow the locking stows to be stripped open during bag lift off leaving the canopy laying on the jumpers back. Therefore, it is imperative that the pack job and the loop length be adjusted to provide sufficient tension on the locking stows to prevent this occurrence. Adjustment of the stow loop may be accomplished by removing the elastic stow loop from its channel and removing and re-stitching to a size appropriate for the task.

D. S-fold the remainder of the lines neatly in the Velcro-closed pouch on the back of the bag.

E. Thread a pull-up cord through the bodkin and then through the free bodkin as shown.



F. Then pull the second bodkin back through the bag while standing the bag up on its end.

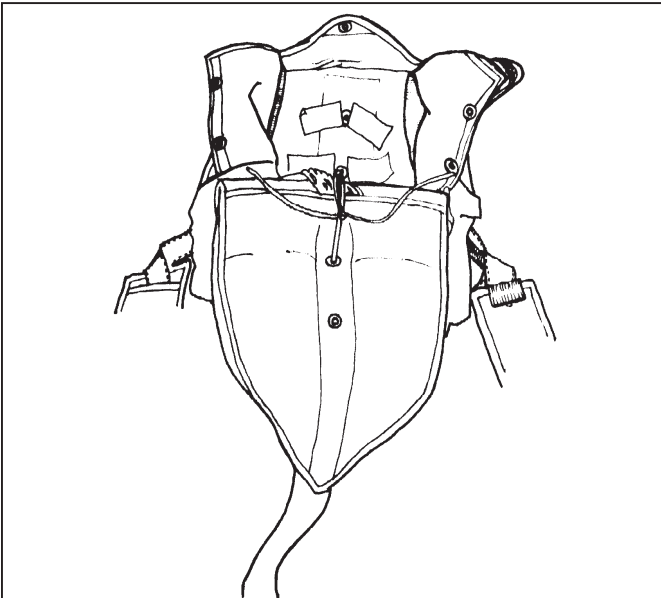

PLACING BAG INTO CONTAINER:

A. Now that the “free” bodkin is through the bag, remove the first bodkin and pass it up through the bottom grommet in the pack tray of the reserve container as shown. Re-thread the pull-up cord through the bodkin.

B. While setting the bagged canopy in the container, use the pull-up cord and top bodkin to pull the bodkin through the bag.

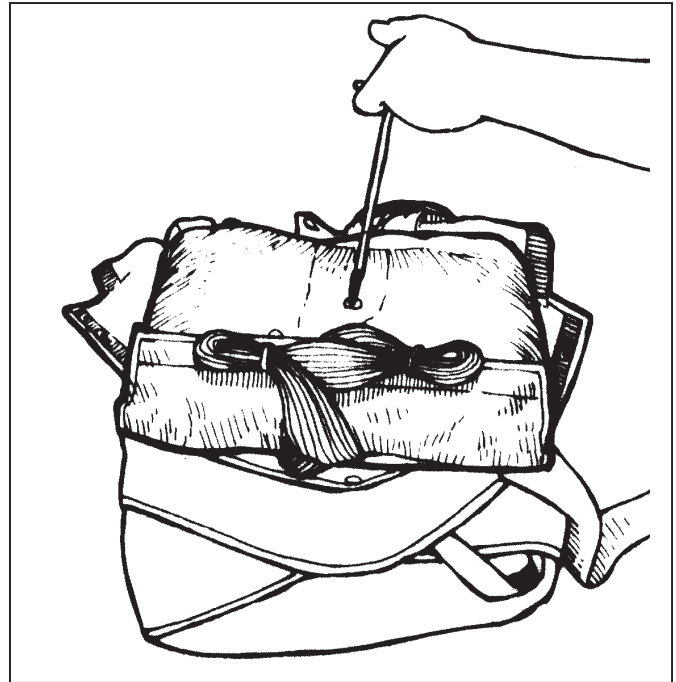

C. Thread the free bodkin through the top grommet in the reserve pack tray and the top grommets of the bag. **TIP:** Maintain the depression in the center of the bag between the two grommets with your knee.

D. Tuck lower corners of bag into lower corners of container.

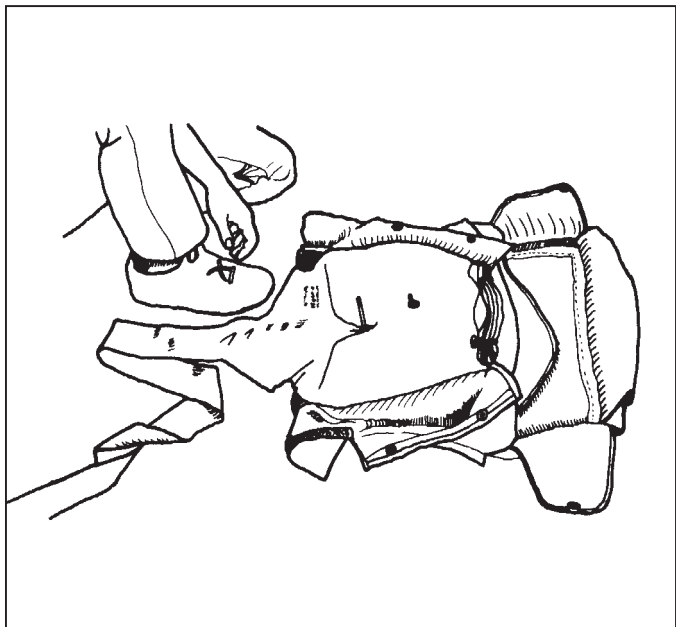

E. Tuck yoke of bag under bag at top of container.

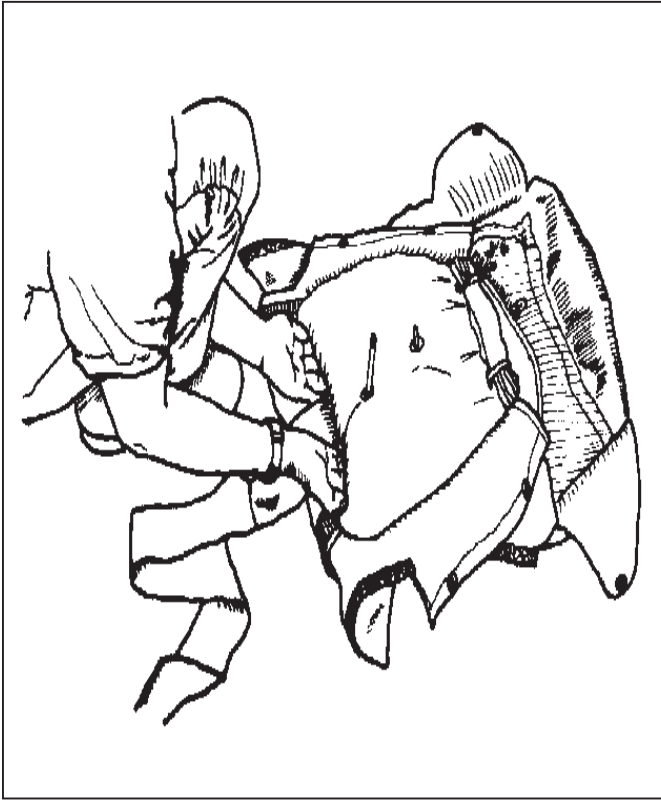

F. Close side flaps of container over bottom bodkin. Close bottom container flap over bodkin. Spread side flaps open to the bottom bodkin.

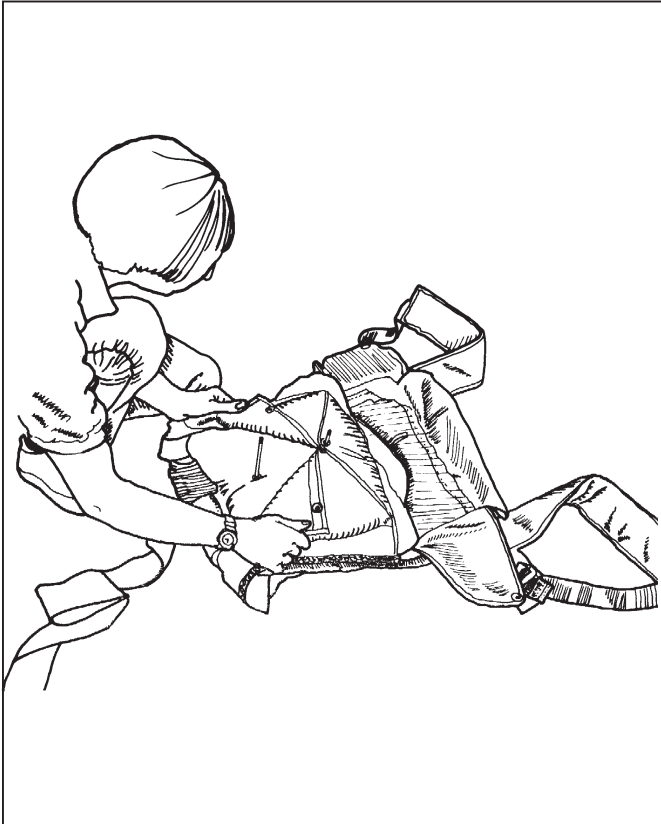

STOWING BRIDLE:

1. Lay bridle down over side flap to establish length of fold.

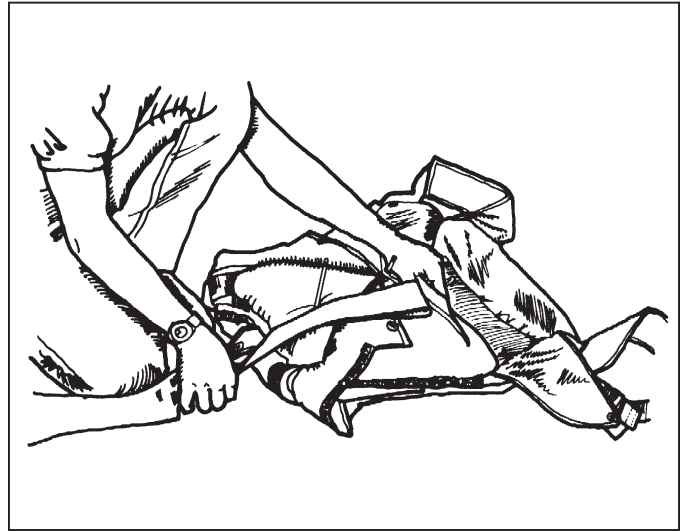

2. Make another fold on top of the previous fold.

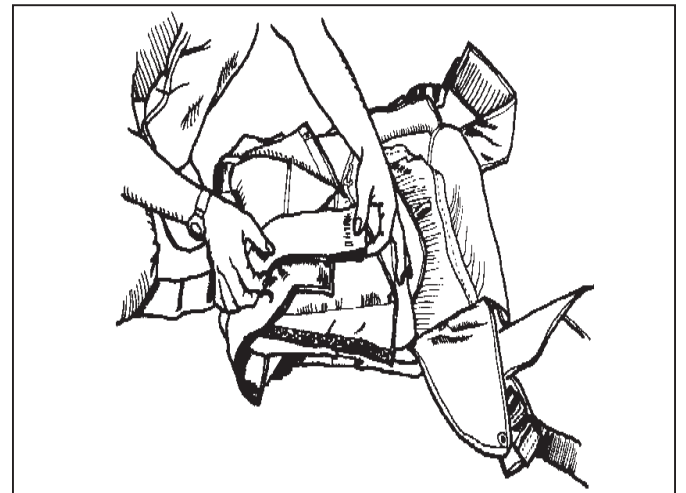

3. Tuck folds under side flap.

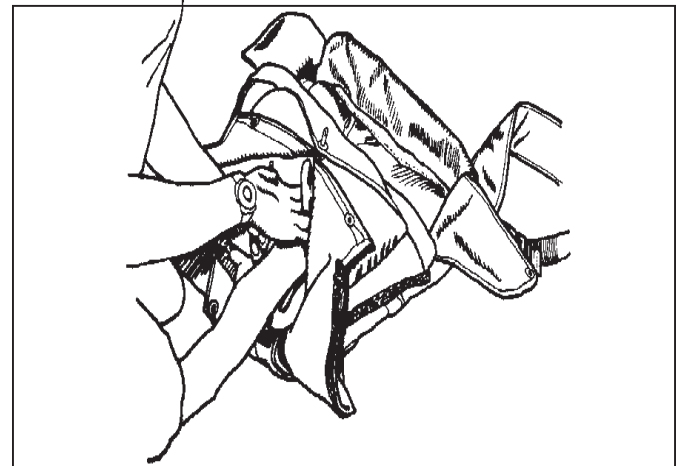

4. Smooth folds of bridle with packing paddle.

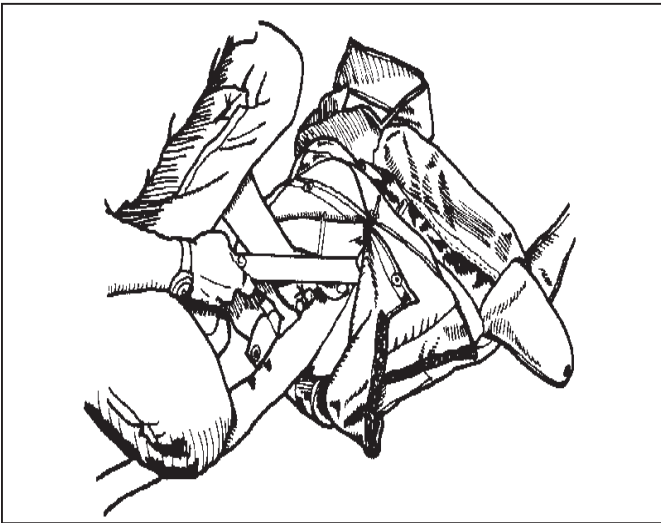

5. Make a 90 degree fold in bridle at center of container and route across container to opposite side.



6. Without twisting the bridle make another 90 degree fold and tuck it under side flap with packing paddle.

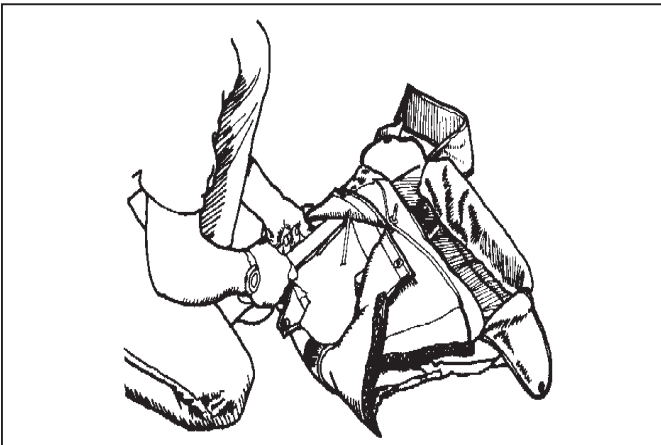

7. Repeat folding procedure from previous side and tuck folded bridle under this side flap while making

another 90 degree fold back to the center of the container leaving approximately 3ft.



GO TO PART THREE.

PART THREE: CLOSING THE CONTAINER

A. Place the top two grommets of the left (or right) reserve closing flap over the top bodkin. The bridle should exit the container between the bodkins. Repeat with the other side.

B. Thread the bodkin through the top closing flap.

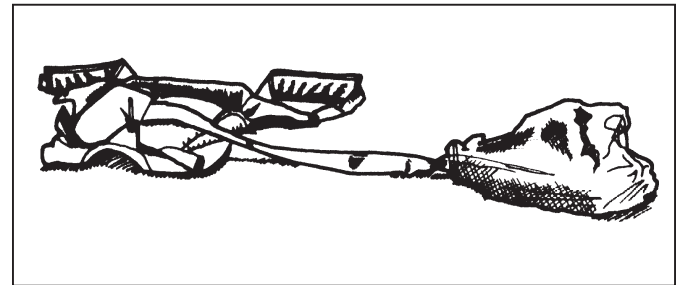

C. Open the quick loop on the pilot chute about four inches on each side for the first pack job. Thread a pull-up cord through each loop.

D. S-fold the reserve pilot chute bridle neatly from left to right between the two bodkins. Make the S-folds about four inches long.



E. Set the pilot chute on the folded bridle.

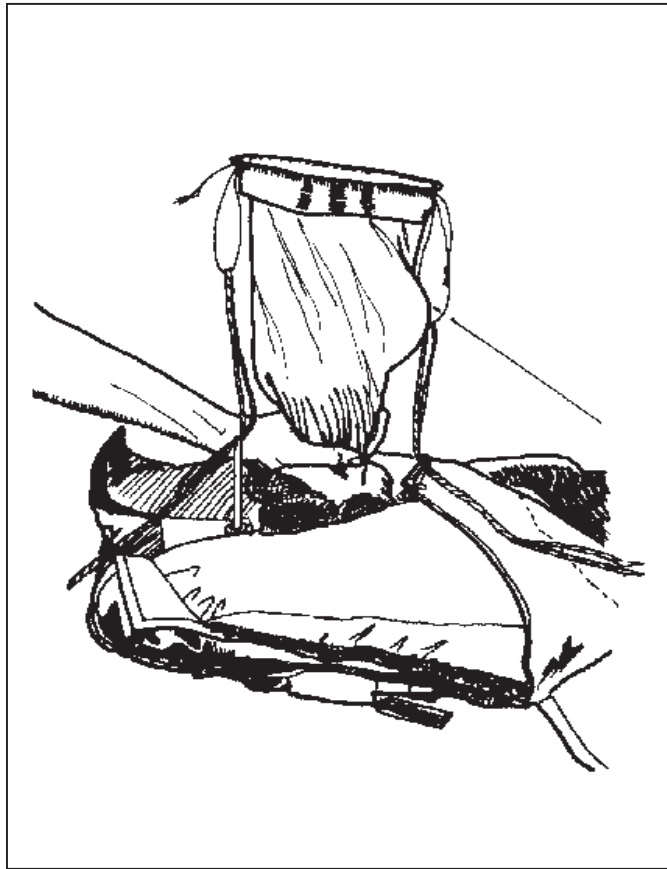

F. Thread the pull-up cords through the bodkins.
G. Compress the pilot chute to the container. Holding it compressed, flip the rig over onto its back.

H. Slowly pull the pull-up cords through the rig. Make sure no pilot chute or reserve canopy fabric comes through with the pull-up cords.

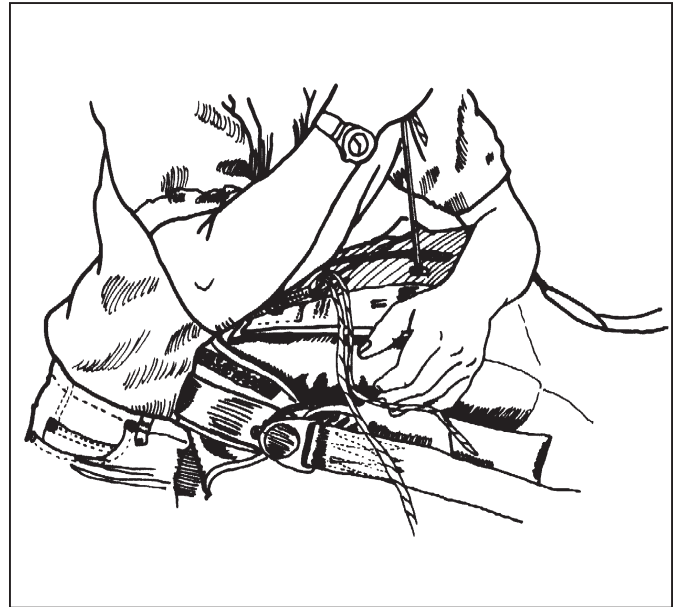

I. Remove the bodkins and pull the closing loops the rest of the way through the grommets, starting with the top one, secure them with the ripcord pins.

J. Turn the container back over and untape or untie the running ends of the quick loop.

K. Push the pilot chute down into position and take the slack out of the quick loop by pulling on the opposite running end. You will have to repeat this step several times until all the slack is out.

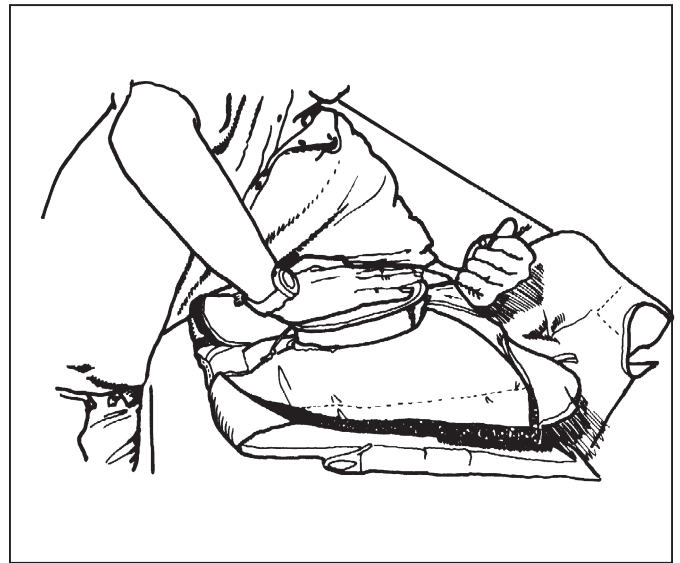

Note: This is your opportunity to seat the pilot chute and adjust the pull force. The SST “Quick loop” system is designed to give the rigger ability to do both of

these things. Remember 22 lbs to move the pins is all that is required.

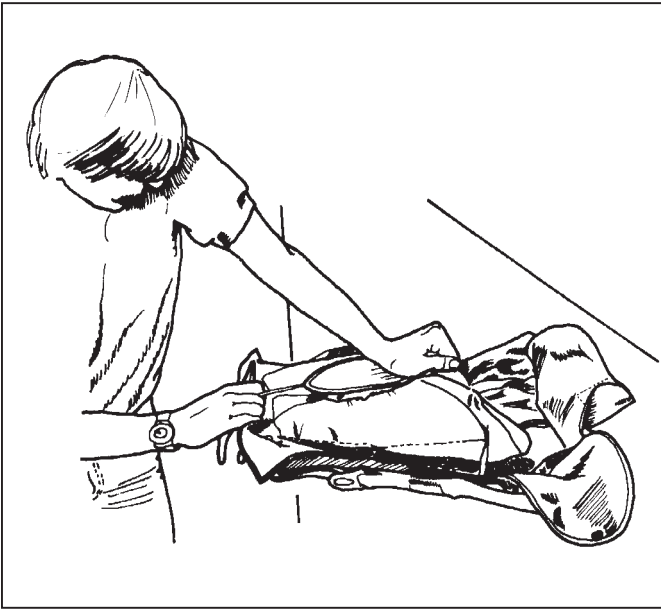

TACKING QUICK LOOP

Note: *THIS STEP IS OPTIONAL.* If the canopy has been carefully packed into the bag and the buffers properly placed and the bag or long folded round canopy has been carefully placed into the container with the buffers properly placed and no canopy fabric is exposed to the area of the quick loop then there is no need to tack the quick loop closed. However, this procedure is provided for riggers who want to use it.

A. Tie the two pull-up cords together to prevent the pilot chute from traveling too far after the pins are released

B. Release the ripcord pins, but keep the pilot chute under control.

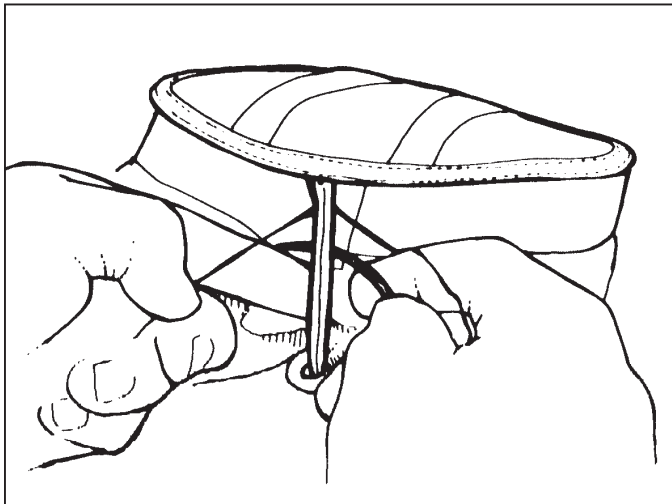

C. With little more than the quick loop exposed, you

should be able to rock the pilot chute top to bottom as the pull-up cords slide. This allows you to access the loop ends for tacking.

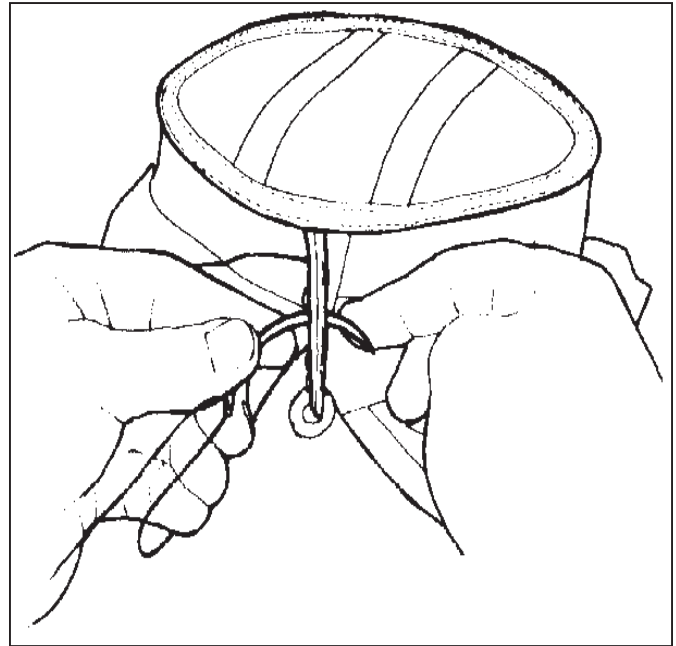

D. Using red rigger's seal tie thread, tack the loops with two passes of overhand stitching. The loop must be tacked within one-half inch of the end. **USE ONLY SEAL THREAD.**

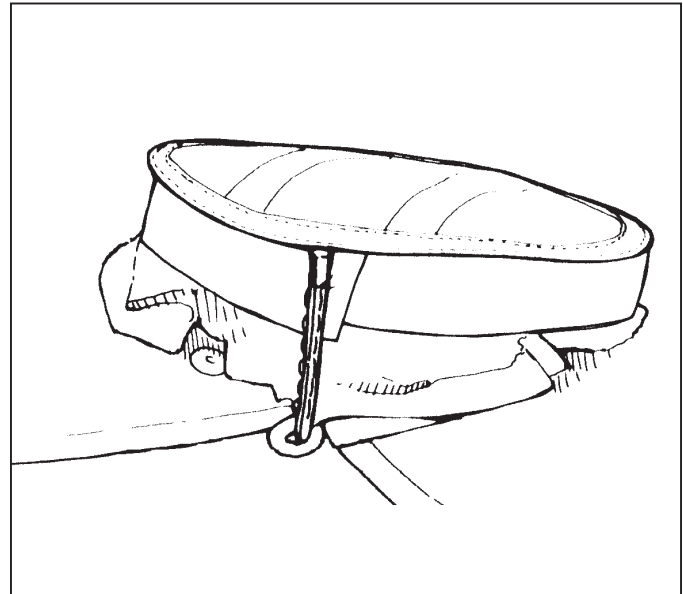

E. Reclose the reserve as above.

F. Remove the pull-up cords.

DRESSING THE CONTAINER

A. On the Racer only, tuck the Type 12 webbing tabs at the top of the container under the side flaps, but over the top of the bag or canopy.

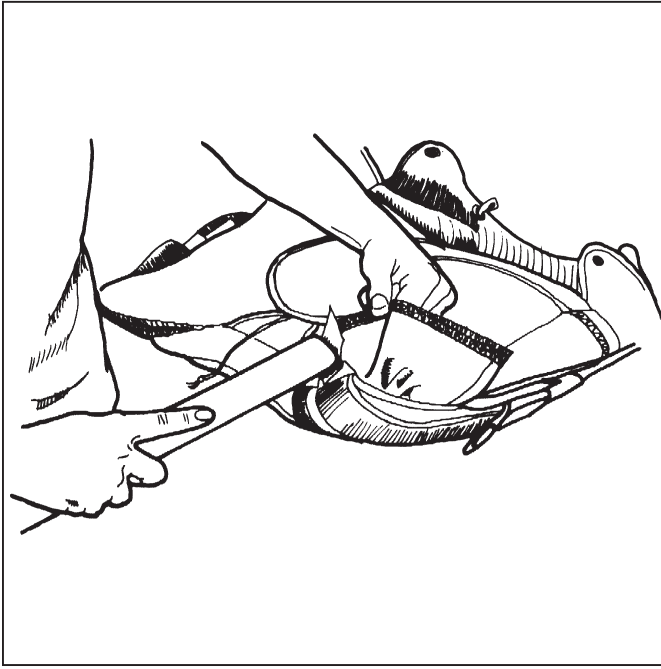

B. Using hemostats or needle nose pliers grip “Quick Loop” pull string about 1/4 inch back from edge of hat and push slack through hole in hat valance into area between top of pilot chute and bottom of hat.

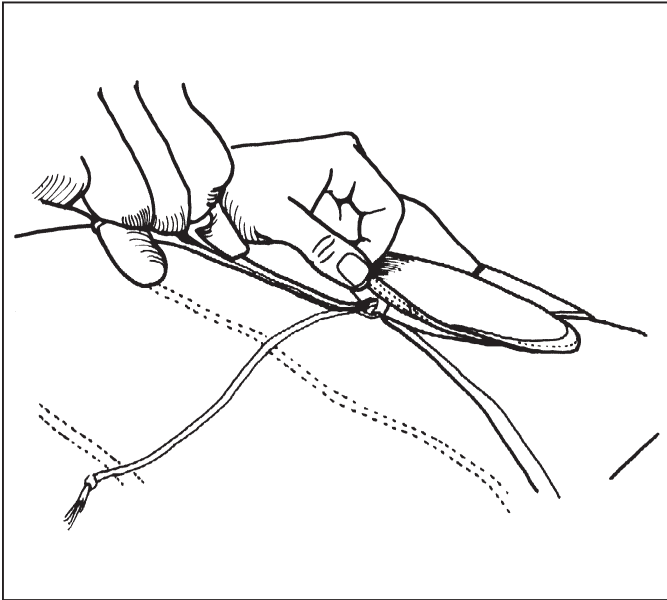

C. Regrip pull string and insert it in its entirety into area below hat.

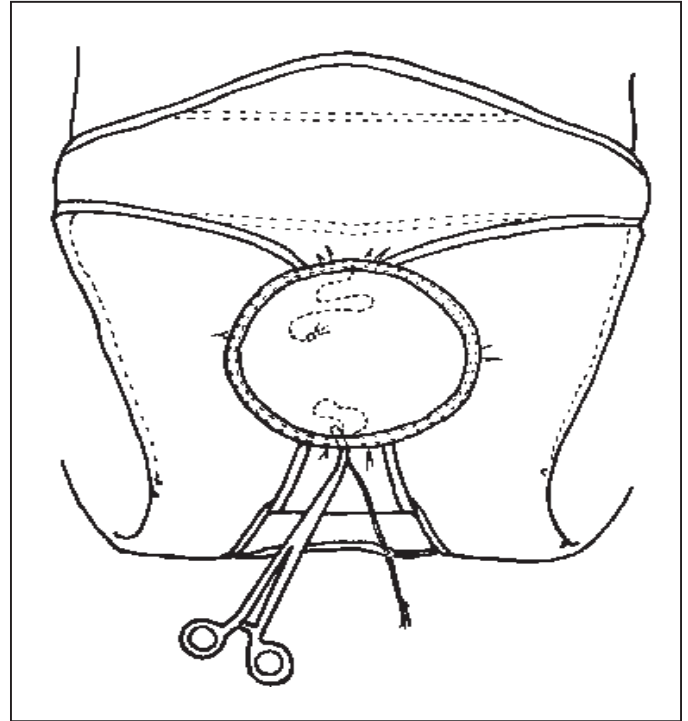

D. Insert packing paddle into opening provided in the bottom corner of the container and run it along the vertical partition shaping and smoothing as you go.

E. Using Packing paddle, tuck in the bottom corners of the vertical partition. Use this opportunity to shape the sides of the container.

COUNT YOUR TOOLS!

Seal the container, fill out the data card, and log.

MAIN PACKING INSTRUCTIONS

Refer to the manufacturer's instructions for laying out, inspecting and folding the canopy, and otherwise preparing it to put into the bag. If you can't find suitable instructions, consult your rigger or call Jump Shack. **Note:** The square canopy packing instructions found in the Type V reserve canopy packing instructions of this manual may be for all tandem canopies and at your discretion for other main canopies.

SETTING BRAKES

Refer to the break setting instructions in the Type V Reserve packing instructions.

FLAG SLIDER INSTRUCTIONS

Pull the slider up to the stops in the same manor you would for a non-flagged slider. Continue to pull the flag portion up towards the top of the canopy until the flag is straight and the grommets are against their stops. The pockets of the flag should be pointing out or exposed. Fold the canopy using the procedure you are most comfortable with, PRO or Side packing. Roll or fold the nose and make the A to B Fold if you are side packing.

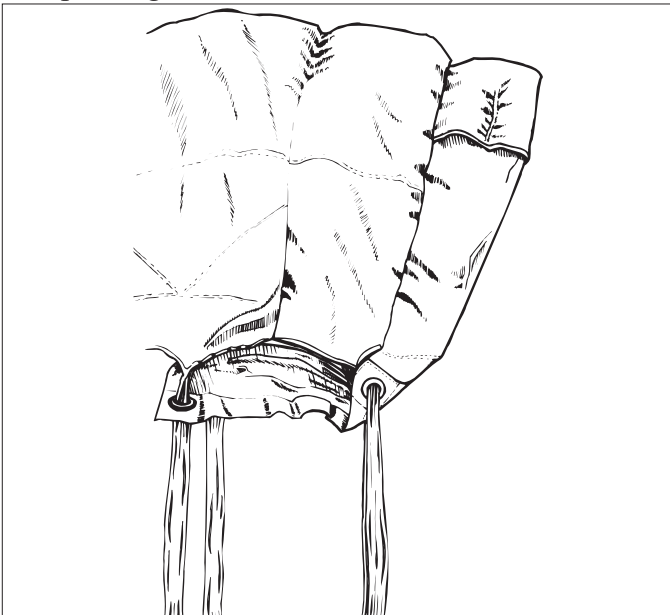

NOTE: The purpose of the flag is to cover the nose

during deployment and for the pockets on the flag to inflate and hold the flag in place covering the nose and slowing inflation.

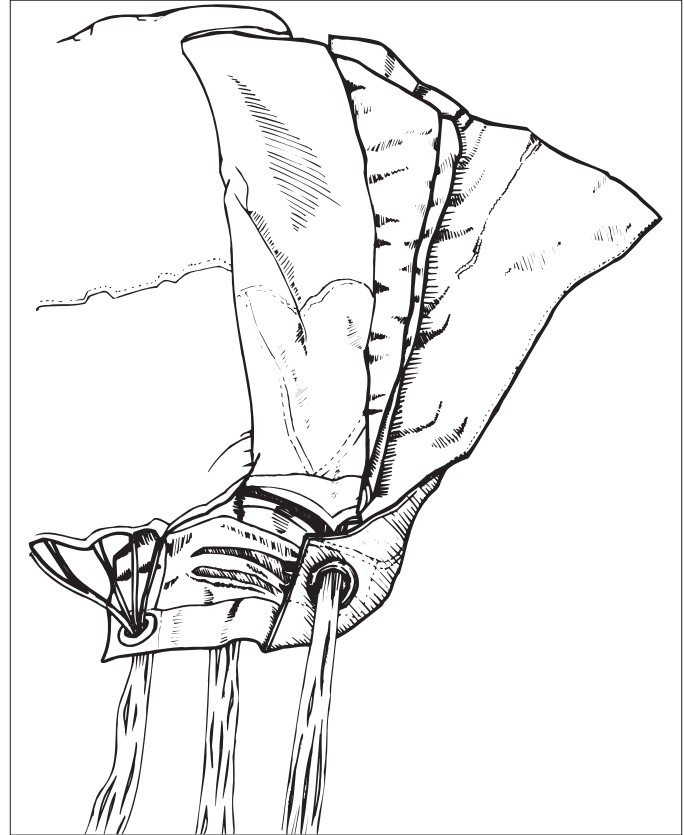

Next wrap the flag around the rolled nose as shown. Continue folding the canopy in the manor you are most comfortable.

PLACING CANOPY INTO BAG

1. Dress the canopy slightly wider than the bag.
2. Stack the canopy into a bundle the height and width of the bag, and insert it into the bag. **MAKE SURE TO FILL THE CORNERS.**
3. Thread one of the two center locking elastic stow bands through its partner grommet. Take a bight of canopy lines 25% of the bag width long, and wrap the stow band around it. Repeat with the other center locking stow.

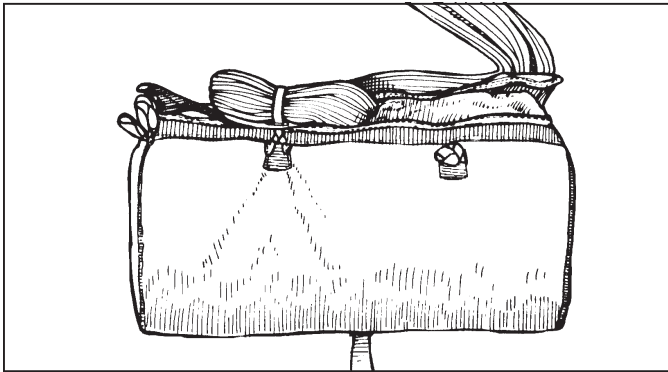

4. Pull the pilot chute bridle out of the top of the bag until the load-bearing ring on the top of the canopy seats against the grommet on the top of the bag. Clear out any extra fabric with your finger.
5. Stow the rest of the lines in bights 25% the width of the bag long into the stow bands on the bottom flap and back of bag of the bag. Leave 8" to 15" of lines unstowed.

PLACING BAG INTO CONTAINER

1. Set the bag in the tray of the container with the lines facing toward the bottom of the rig.

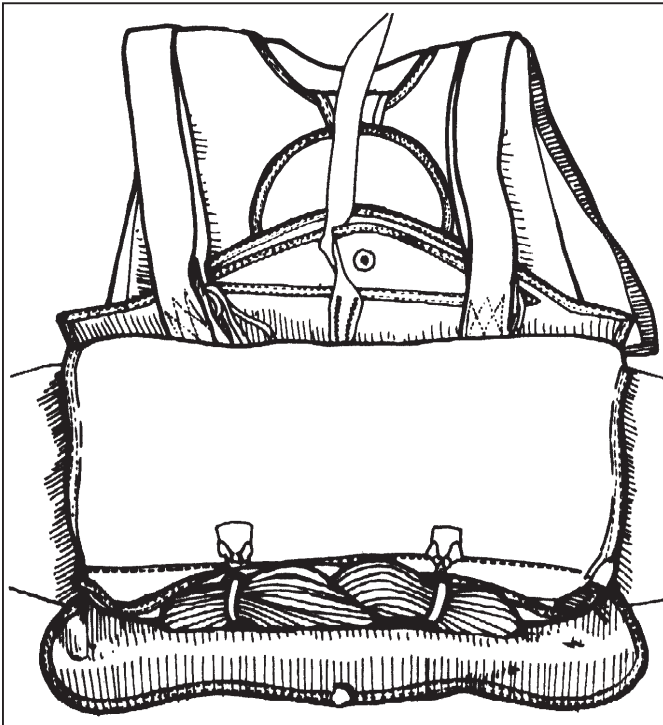

2. Tuck the bights of the line stows under the boxing of each corner of the main container.
3. Thread the pull-up cord through the closing loop.

4. Close the bottom three flaps, bottom, side, side. Insert pin temporarily.
5. Now is the time to "Saddle Bag" the container; that is, lift up on the center of the sides of the container to expose the vertical partition at the bottom of the reserve container. This provides an opportunity to stuff the bag down into the bottom corners of the main container and to place the risers and links against the bottom of the reserve container and off the floor or pack tray of the container where they would dig into your back.

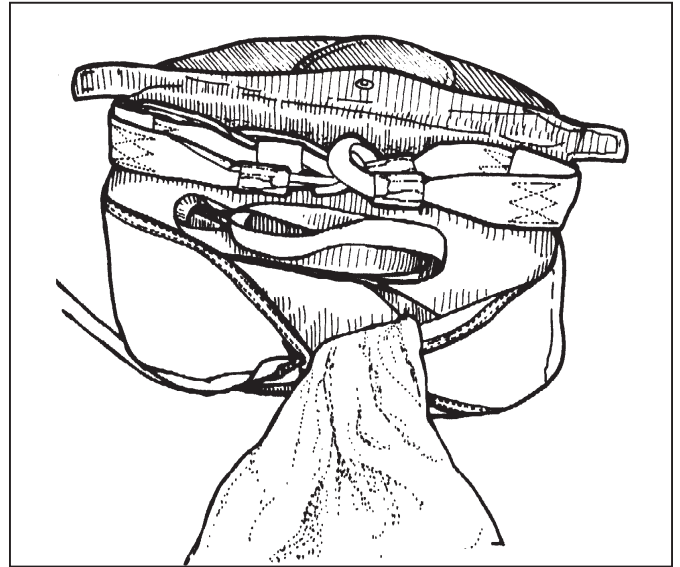

FOR PULL-OUT

- A. Remove the pin.
- B. Route the lanyard and handle under the right hand side flap. (Note: This step may be performed before the initial closing or "Saddle bagging").



C. S-fold the pilot chute bridle across the top of the container, and lay the pilot chute in the top center of the bag (THE DEPRESSION CREATED BY THE CLOSING LOOP MAKES AN EXCELLENT RECESS FOR STOWING THE PILOT CHUTE) with the base coming out of the right-hand bottom corner.

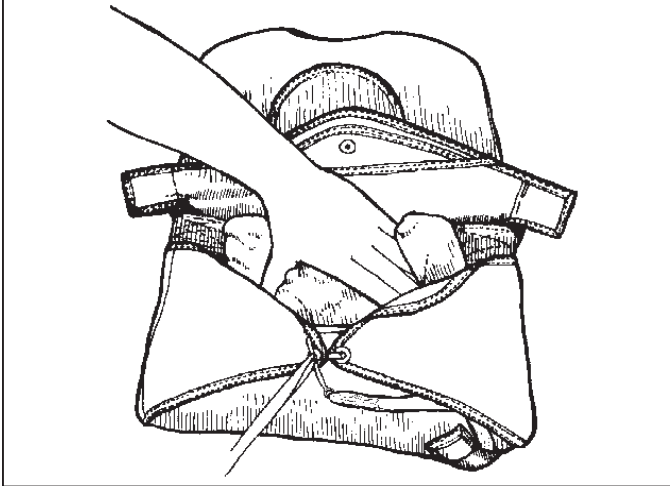

D. Place the lanyard end of the handle into the elastic pouch on the bottom right corner of the container. Bend the handle enough to slip the end tab into the other square pocket on the bottom of the container.

E. Close top flap.

F. Insert the pin on the lanyard at the base of the pilot chute through the closing loop from bottom to top. Remove the pull-up cord.

FAILURE TO REMOVE THE PULL-UP CORD WILL RESULT IN A PILOT-CHUTE-IN-TOW MALFUNCTION.

G. Check to see that the velcro on the lanyard is mated to the velcro on the pilot chute retainer. This is to assure enough slack movement of the lanyard to be able to pull the pin without moving the pilot chute.

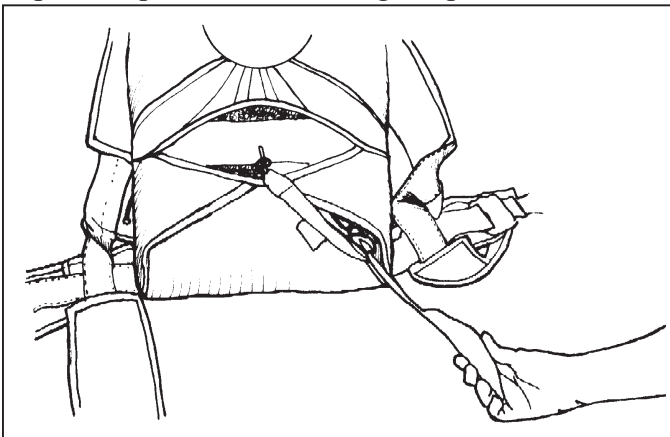

H. Stow any excess lanyard under the right side flap.

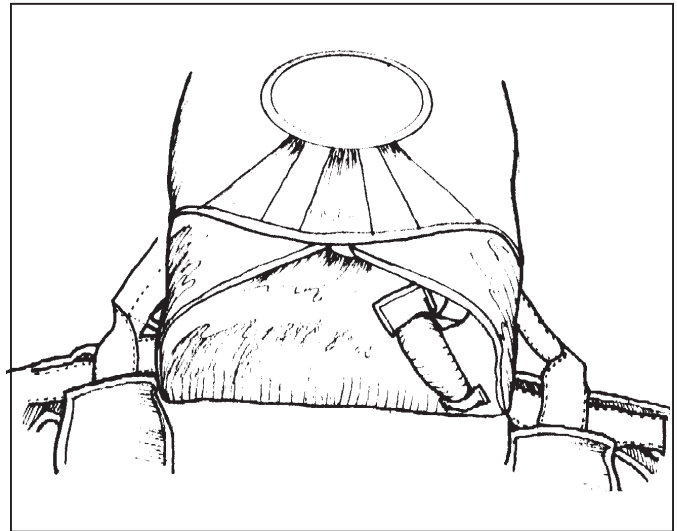

Always have your SST checked by someone competent after you put it on.

FOR THROW-OUT

A. Route the bridle out the top right.

B. Close the top flap.

C. Remove the pin.

D. Insert the curved pin through the closing loop on top of the top flap from right to left.

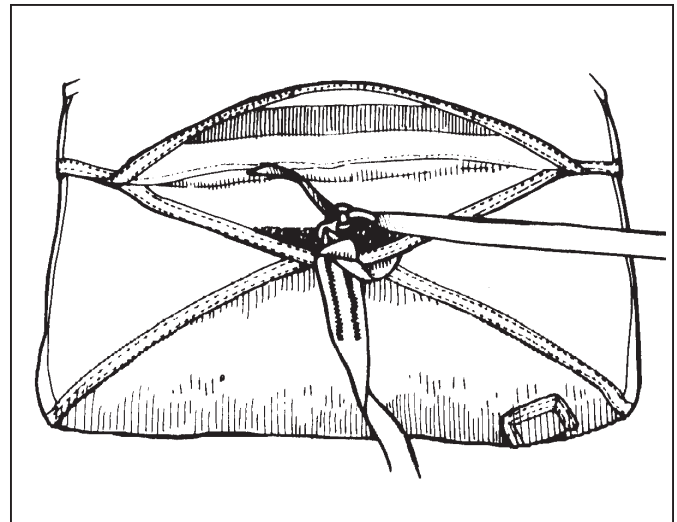

Remove the Pull-up cord. FAILURE TO REMOVE THE PULL-UP-CORD WILL PREVENT THE CONTAINER FROM OPENING AND RESULT IN A PILOT-CHUTE-IN-TOW MALFUNCTION.

E. Mate the small velcro strips on the pilot chute bridle just above the curved pin. FAILURE TO MATE THE VELCRO STRIPS CAN RESULT IN A PILOT-CHUTE-IN-TOW MALFUNCTION. Close the pin-inspection flap.

F. Check to make sure the leg strap is not twisted. Mate the velcro on the pilot chute bridle starting from the top of the pouch on the leg strap and following along the side of the container. Stuff any extra bridle under the right-side container flap.

FOLDING THE THROW-OUT PILOT CHUTE

A. Lay the pilot chute mesh-side-up over the leg strap, with the edge of the pilot chute at the mouth of the pouch. Turn the pilot chute until the bridle has no twists.

B. S-Fold the bridle radially over the half of the pilot chute closest to the bridle's entry.

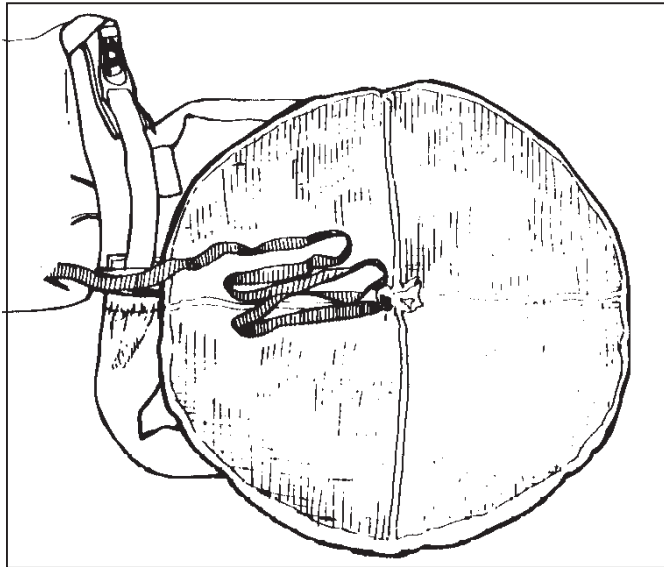

C. Fold the pilot chute in half over the bridle.

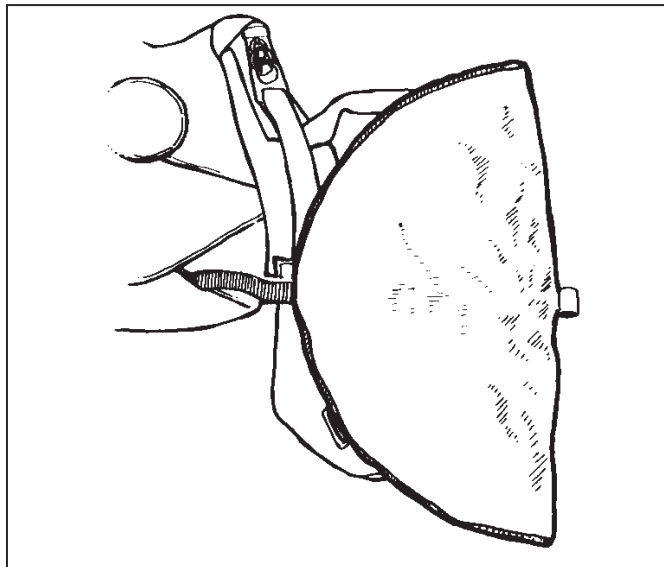

D. Take the corners of the semi-circle and fold one over the other into thirds.

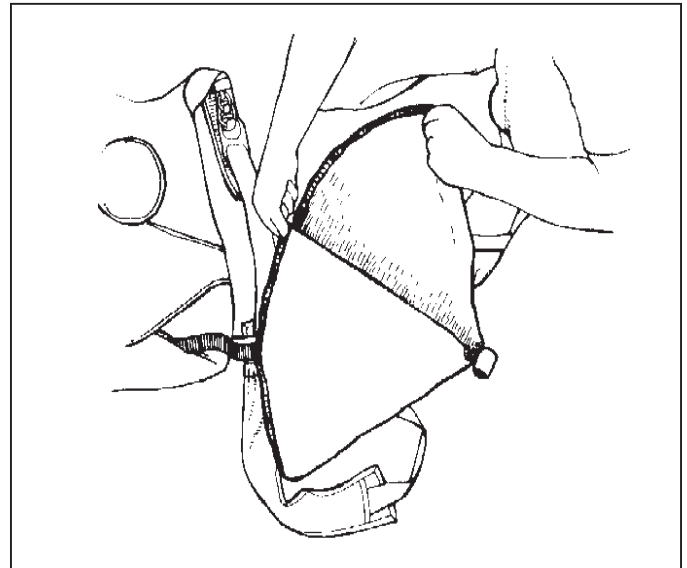

E. Fold the pie-shape into thirds again.

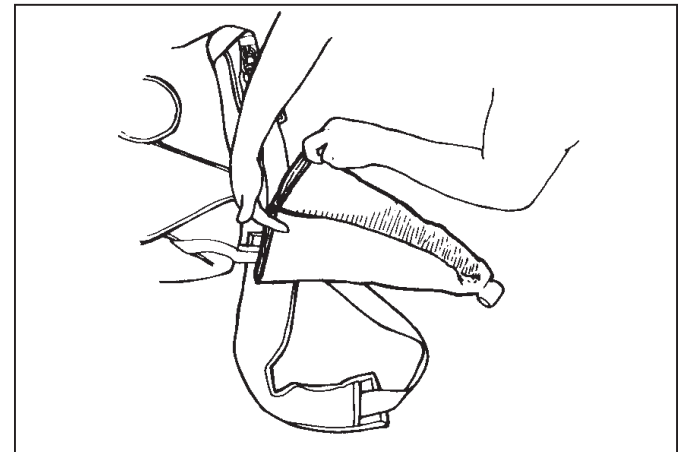

F. Fold the new thin pie shape in half to make it even thinner. Fold the handle over to the mouth and place it into the pouch. (You will have to peel back a little bridle velcro to keep from pulling any bridle out of the folded pilot chute.)

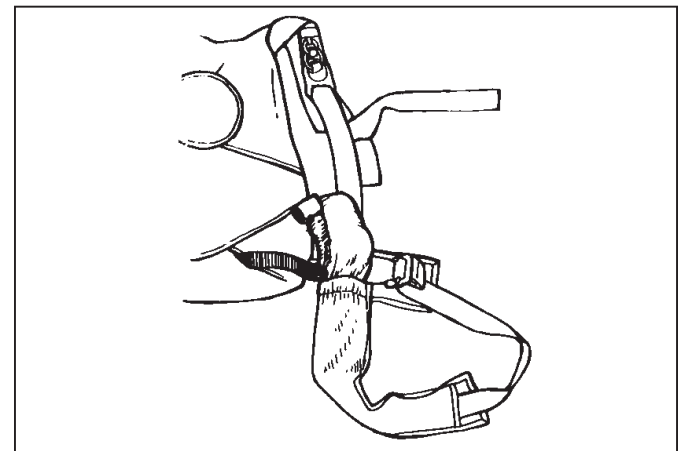

G. Flatten out the bundle, and make sure nothing but the handle of the pilot chute sticks out of the pouch.

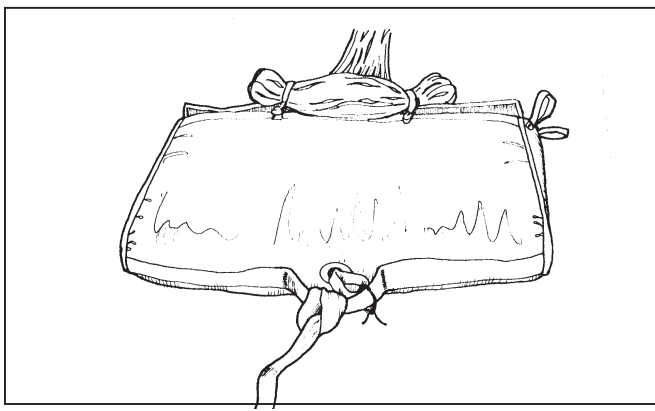
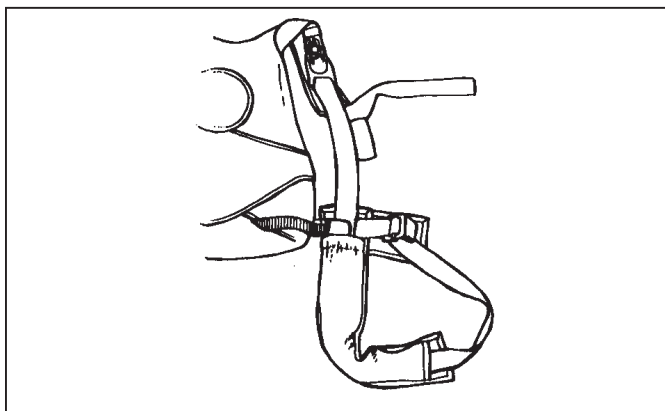

H. CHECK THE BRIDLE ROUTING. AN IMPROPERLY ROUTED BRIDLE MAY RESULT IN A PILOT-CHUTE-IN-TOW MALFUNCTION.

Always have your SST checked by someone competent after you put it on.

FOR RIPCORD

A. Thread the ripcord through its housing, and place the handle in its pocket.

B. Thread the pull-up cord through the closing loop.

C. S-fold the pilot chute bridle neatly on top of the bag.

D. Compress the pilot chute and hold it under the center of the bottom flap grommet. Insert pin.

E. Thread the pull-up cord through the bottom, left, and right container flap grommets. Pull the closing loop through as you go, holding the pilot chute in place on the top center of the bag under the center of the bottom flap grommet.

F. Insert pin.

G. Thread pull-up cord through top grommet and close top flap.

H. Remove pin and reinsert above top flap. Remove the pull-up cord. FAILURE TO REMOVE THE PULL-UP-CORD WILL RESULT IN A TOTAL MALFUNCTION OF THE MAIN CONTAINER.

NOTE: IT SHOULD REQUIRE NO MORE THAN 15 POUNDS TO EXTRACT THE PIN FROM THE LOOP AFTER THE CANOPY IS PACKED.

Always have your SST checked by someone competent after you put it on.

FOR STATIC LINE

A. Attach the static line to the top of the deployment bag by looping it through itself around the type 8 bag bridle.

B. Thread the canopy's bridle intermediary loop (the 9/16 tubular loop from the assembly section) from the inside of the bag through the grommet in the top of the bag.

C. Tie it to the same webbing used in step "A", but not to the static line itself, with two turns of 1/4" Type 1 (80#) cotton break-cord.

NOTE: For conversion to pilot chute deployment simply unthread the static line. Then thread on the pilot chute bridle, but with the pilot chute bridle you MUST encompass the 9/16 tubular loop bridle intermediary where the break cord is. There is no need to remove the break cord as it will be needed the next time the rig is used for static line. To convert back to static line simply remove the pilot chute bridle and loop the static line onto the bag bridle of type 8 but DO NOT encompass the 9/16 tubular loop bridle intermediary as it MUST be allowed to separate when the break cord is activated.

D. Route the static line out the top of the container on the side opposite the door of the jump ship. (A right-side jump door usually calls for a left-side static line routing.)

E. Close container as you would for a ripcord rig. Insert static line curved pin.

F. Remove the pull-up cord. FAILURE TO REMOVE THE PULL-UP-CORD MAY RESULT IN A STUDENT-IN-TOW OR SEVERE CONTAINER DAMAGE.

G. Stow the static line in the compartment provided in the elastic stow bands.

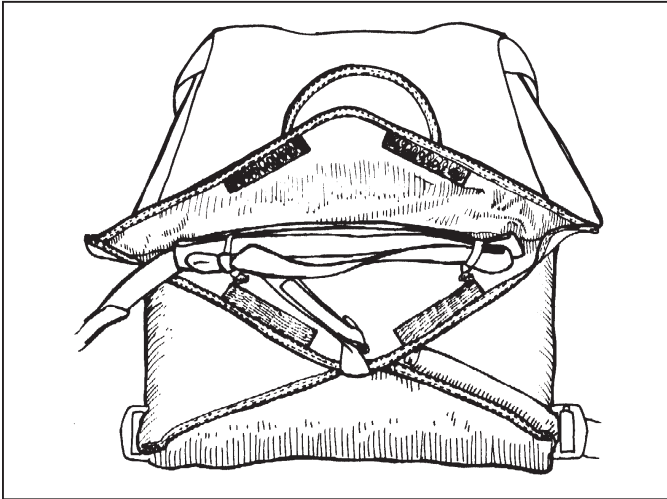

NOTE: The first stow in the rubber band of the

static line should be doubled or tripled to prevent the prop blast from prematurely blowing the pin out and allowing an open container.

DRESSING THE CONTAINER

A. After closing the top flap the rig is set up on its side. With your thumb hold the main risers against the bottom side of the over the shoulder part of the harness. Place the risers in the riser covers and mate the velcro. For the Elite, route the risers over the outside edge of the shoulder and begin closing the riser cover at the mid-flap working your way to the top of the shoulder.

B. Pull the side (Epaulet) flap over the top of the riser cover and mate to its velcro patch.

Tandem Drogue & Main Container Closing

Cock the drogue/main pilotchute if your system is so equipped. Pull the excess “kill line” up into the canopy. “S” fold the main canopy into the main deployment bag and insert the deployment bag into the main container as described and shown in the Main Packing Instructions.

Closing The Main Container

It is important to position the bag squarely into the container, filling out the bottom corners of the container tray. This will prevent the bag from “floating” out of the tray in the event of a premature main container opening.

Note: The Elite Tandem main container bottom flap is fitted with two closing grommets. The one located closest to the outside edge is assembled into a triangular shaped addition to the standard bottom closing flap. This grommet is used for the first level closing as follows.

First Level Closing

Insert your pull-up cord through the “Thru Loop” located in the tray of the container.

Bring the pull-up cord up and over the top of the main bag and through the grommet located closest to the edge of the flap.

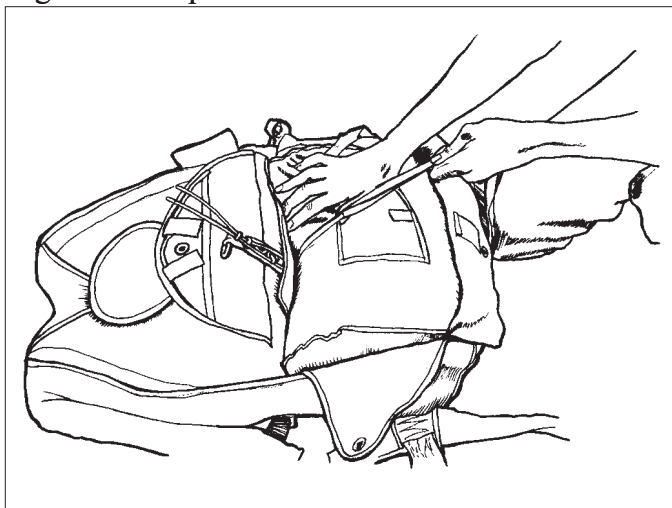

Close the side flaps over this same grommet, then thread the pull-up cord through the top subflap and close it over the loop.

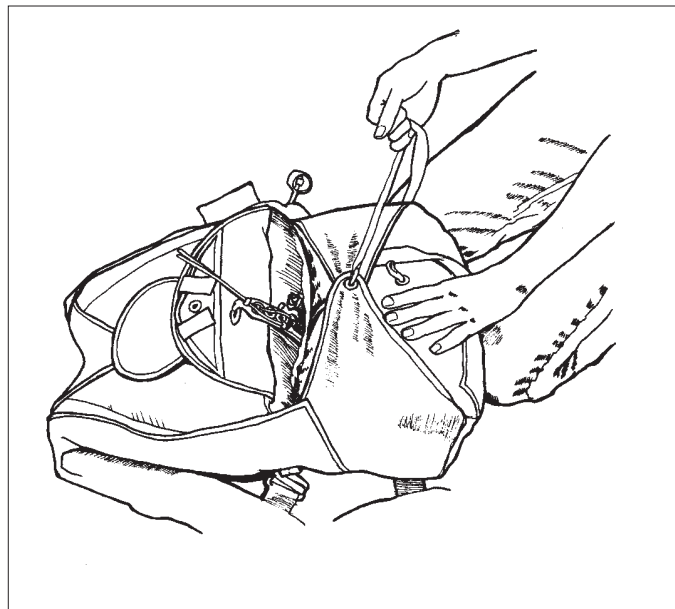
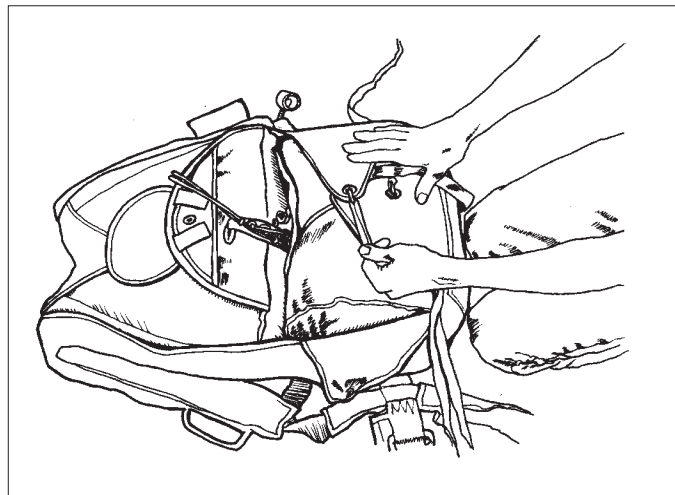
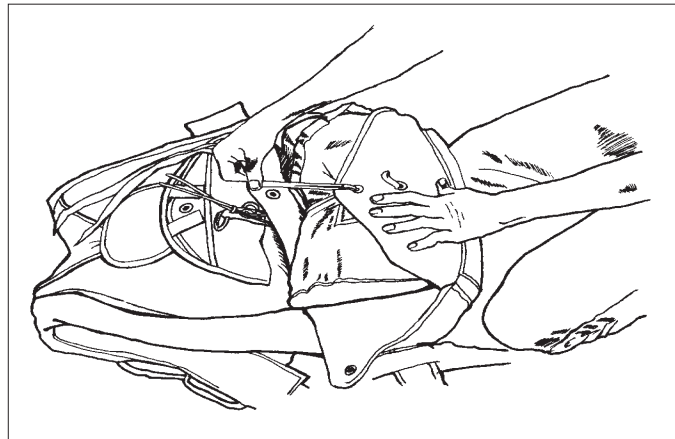

Pin the closing loop with the flexible pin on the bridle. This pin is located about 1 foot from the bag.

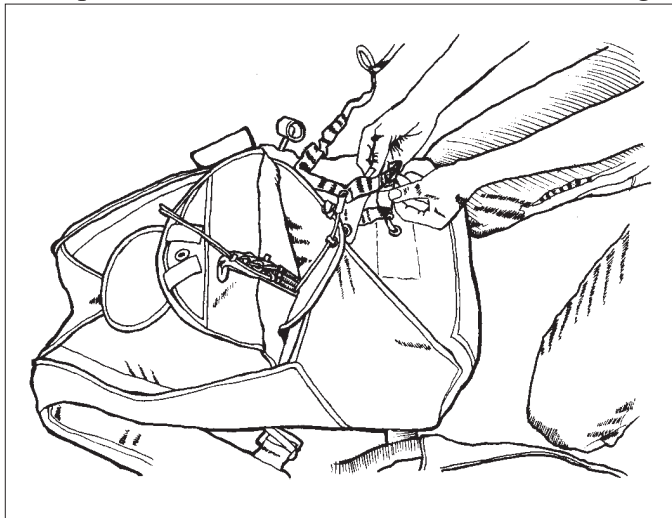

Mate the Velcro on the bridle to ensure proper pin movement during pin extraction.

Bridle Release Assembly

Note: There are three grommets on the bridle retainer support harness, or drogue riser. The top grommet accommodates the THIRD drogue release mechanism. The small ring with the attached loop threads through this top grommet, and is retained by the third cable of the cutaway handle. The small ring should be pre-assembled to the bridle retainer harness.

With the large ring facing the reserve container, and the bridle portion facing the main container, begin to assemble the 3-Ring drogue release. Insert the middle-size ring through the large ring, again facing the reserve container. Insert the small ring through the middle ring and fold it into position to receive the closing loop.

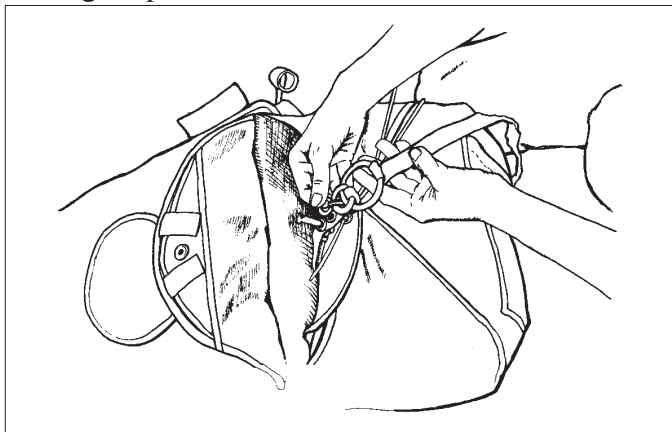

The double-ended loop should be pre-assembled to one of the two remaining drogue release cables (either the primary OR the secondary release cable). One end

of the double-ended loop is inserted through one of the two open grommets on the bridle retainer harness or drogue riser.

Route the double-ended loop over or through the small ring, depending on which end you are starting from, and through the remaining grommet where it is pinned with the last drogue release cable. Each cable should go through ONE loop of the 3-Ring release system, then all three cables can be routed through the Guide Loop at the top of the drogue riser. The Guide Loop is not a functional part of the drogue release system.

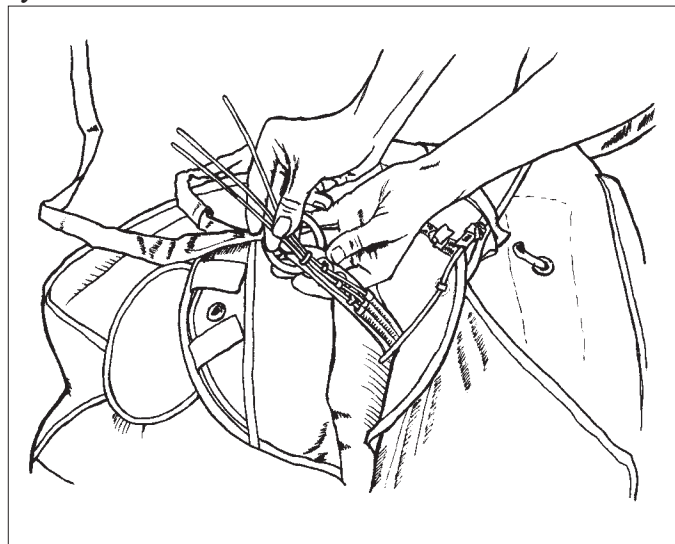

The drogue release cable ends should be inserted into the channel of the bridle, above the large ring.

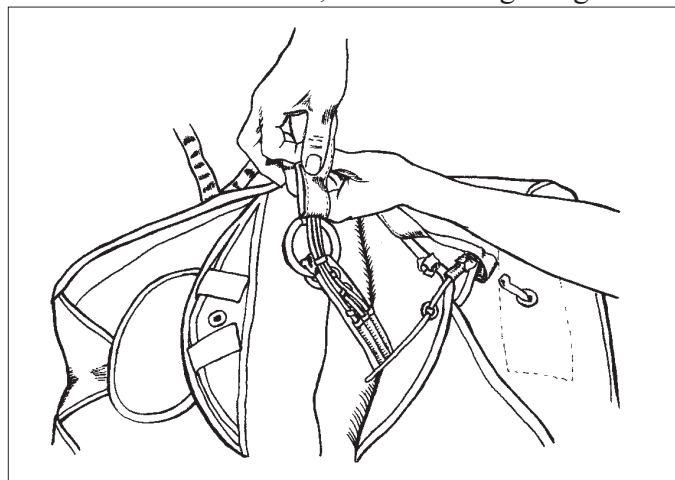

Part of the excess bridle length, between the first main pin and to a point about eight inches from the base of the large ring, must be stowed in the hesitator loop rubber band provided on the top main sub-flap. Double the rubber band over this portion of the bridle. Some slack (about eight inches) must exist between

the base of the 3-Ring system and the “S” folded portion of the bridle, to allow the bridle to “sit up” out of the container during drogue fall. This step is critical to prevent accidental activation of the main pin during droguefall.

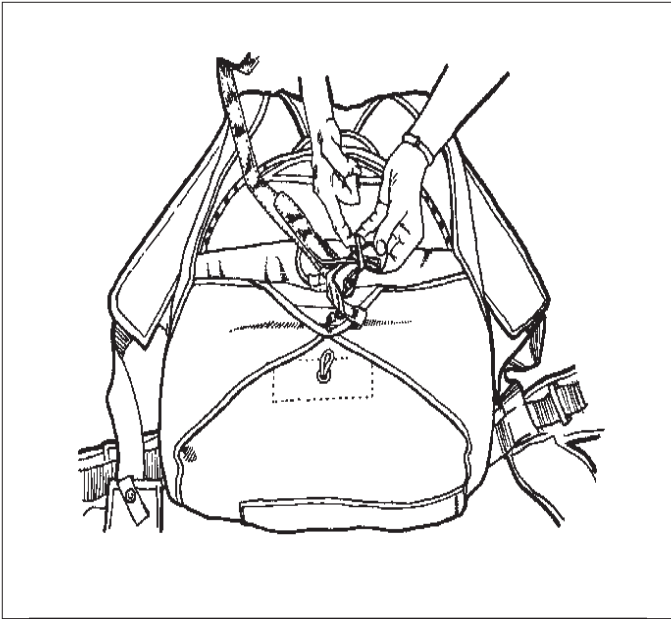

Push entire assembly down toward the backpad as far as it will go comfortably. “S” fold the remaining bridle from side to side on top of the compartment that you have just pushed the 3-Ring assembly into. Leave the second (curved) pin out, to lock the midflap.

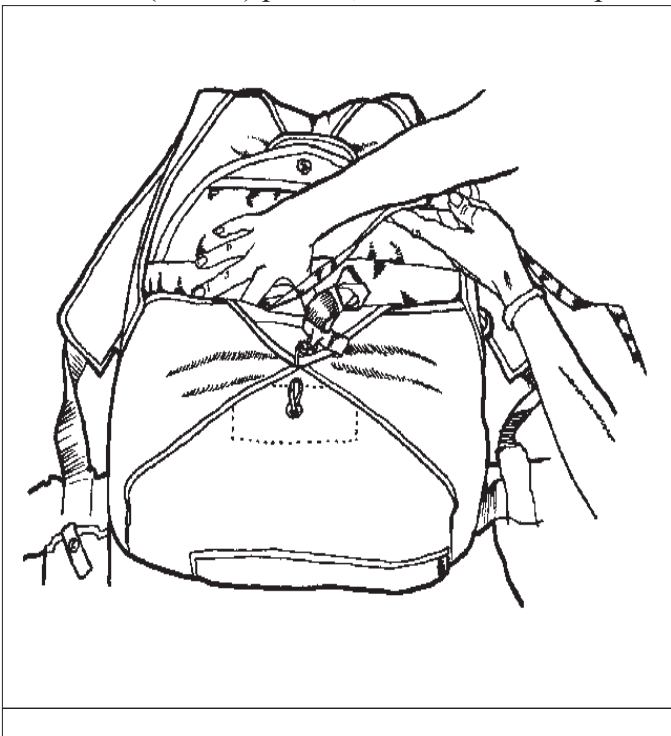

Second Level Closing

Close the midflap as you would a standard Racer with throw-out pilotchute, and pin it with the curved pin.

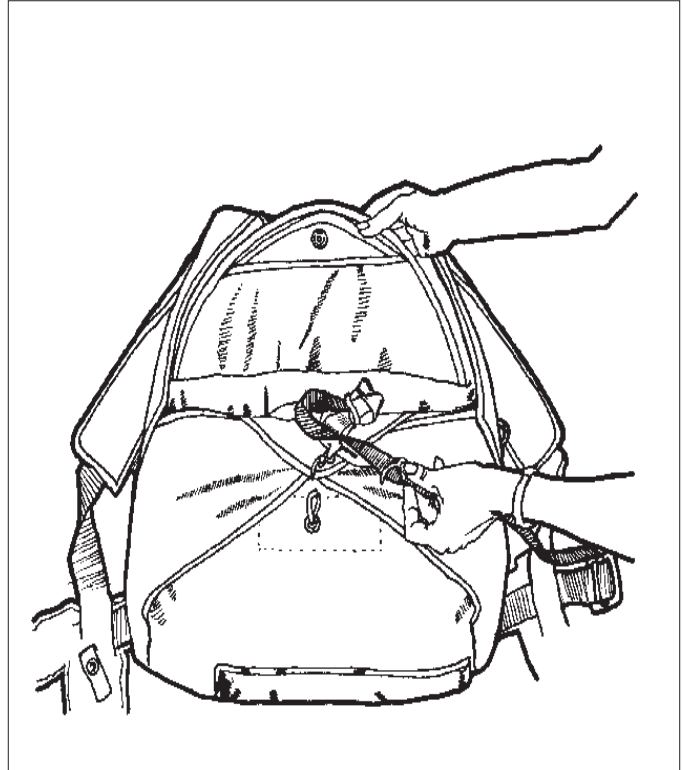

Tuck the bridle under the right side flap edge and to the pouch provided.

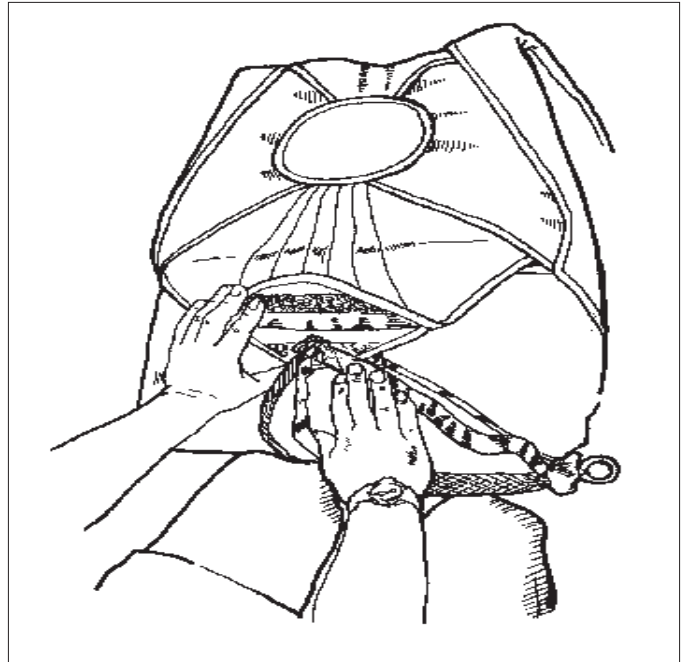

Double check the drogue centerline to verify it has been “cocked,” if so equipped. The apex of the pilotchute should be about even with the skirt when cocked.

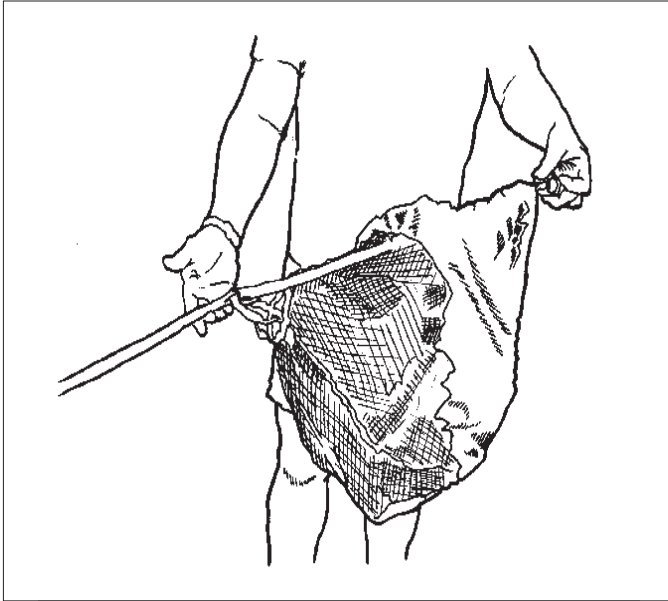

Note: It is necessary to pull the excess “Kill Line” up into the drogue canopy. This will prevent premature failure of the “Kill Line”

Fold the drogue/pilotchute into 1/8 pie sections, and insert it into the spandex pouch on the bottom of the container. Dress the bridle to assure that none is exposed.

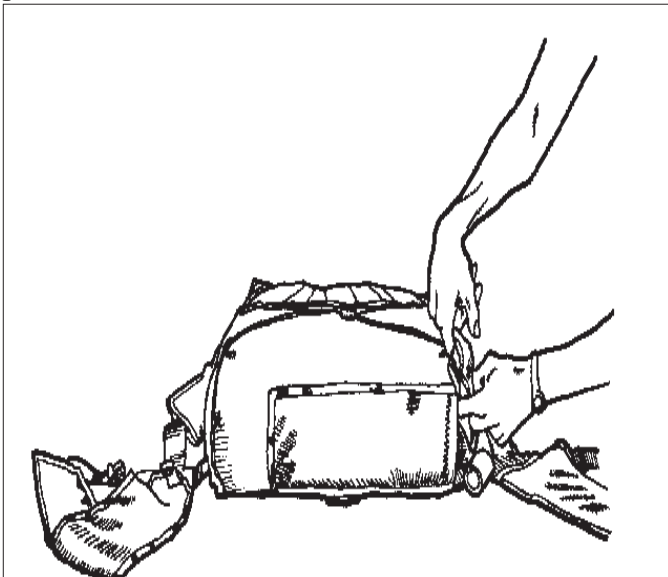

DONNING THE SST

Before donning your SST you should check the reserve ripcord pins, make sure that the seal is intact, the pins are properly seated and there are no foreign materials in the housing.

1. Grasp the SST by the harness at one of the canopy release points, and put it on your back like a coat. Check for twists in the main lift webs (front straps) and leg straps.

2. Hook up the leg straps:

WITH THREAD THROUGH LEG STRAPS

A. Check the leg strap for twists as you pass it under your leg.

B. Bring it through the friction adapter from the side against your leg and over the sliding bar.

C. Continue over the sliding bar and back through the friction adapter.

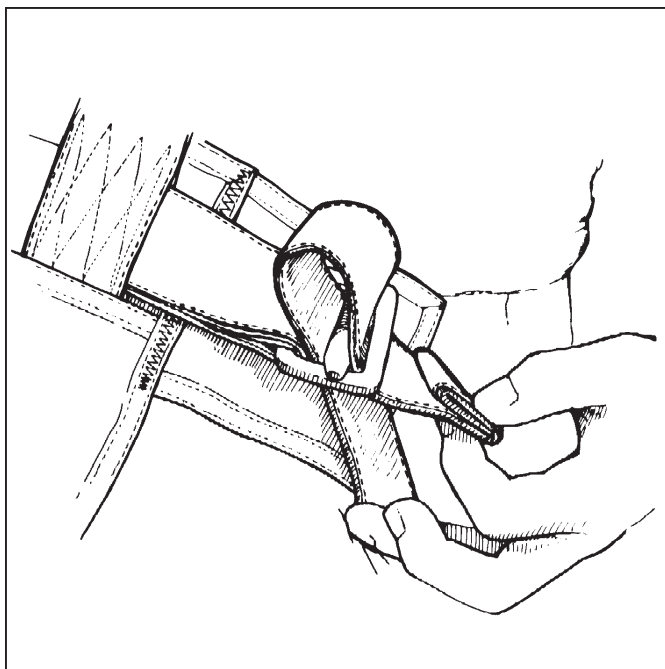

MIS-THREADING THE LEG STRAP THROUGH

THE FRICTION ADAPTER MAY CAUSE YOU TO FALL OUT THE BOTTOM OF THE HARNESS.

D. Repeat with the other leg strap. Tighten the free ends until snug, and stow them away.

WITH B-12 LEG STRAP SNAPS

A. Check the leg strap for twists as you pass it under your leg.

B. Snap the hook onto the V-ring. It should “clink” when it closes the snap.

C. Repeat with the other leg strap. Tighten the free ends until snug, and stow them away.

WITH THROW-AWAY HAND DEPLOYMENT, A TWISTED OR OTHERWISE MISROUTED RIGHT LEG STRAP WILL RESULT IN A PILOT-CHUTE-IN-TOW MALFUNCTION.

3. Locate the chest strap, and thread it like the leg straps.

MIS-THREADING THE CHEST STRAP MIGHT CAUSE YOU TO FALL FROM THE HARNESS.

Pull the free end until the main lift webs are parallel. Place the free end in the elastic keeper.

Should your system be equipped with adjustable laterals, bend at waist, setting rig so it is comfortable on your back. Tighten lateral free ends at container base until the SST fits snugly. (SSTs equipped with Throw-Outs will have an adjustment on the left side only). Stow free ends under elastic keepers. Owners of pull-out should take special note of proper stowing, as an unstowed lateral feels much like a pull-out handle. Repeat adjustment until comfortable fit is obtained.

FAMILIARIZATION

Now that you have learned how your rig works (OPERATIONAL CHARACTERISTICS), the environment wherein it works best (OPERATIONAL LIMITATIONS), how to assemble and pack it (ASSEMBLY, RESERVE PACKING INSTRUCTIONS, MAIN PACKING INSTRUCTIONS), and how to put it on (DONNING THE SST) it is time to learn how to use it. This manual is not intended to provide a curriculum on Skydiving, you *MUST* have completed an approved (by your national Aero club) course before you even think about taking to the air by yourself. But now that your new rig is packed and you have it on let's get familiar with it.

There are three handles that you may have occasion to pull. They are the main, the cut-away and the reserve. Let's talk about the main first.

MAIN ACTIVATION

PULL-OUT

To learn about the activation of the pull-out, lay on your chest in a skydiving arch, locate the pull-out handle on the bottom right corner of the rig with your right hand while your left hand compensates for level fall. Don't bother looking. You can't see it and you will need to be looking at traffic and altitude while you are actually skydiving. Insert your two center fingers between the two retainers of the handle and remove the handle. While gripping the handle thrust downward by extending your arm straight down along the side of your body.

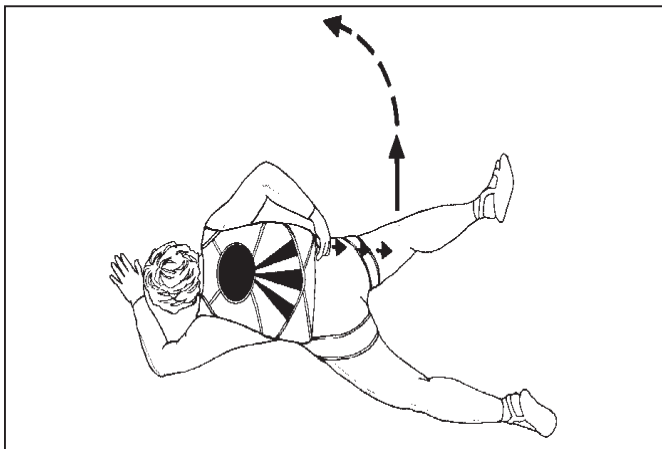

This action will open the pack and allow you to toss the pilot chute into the air stream to the right of your body while you simultaneously look up over your head to watch the deployment. **KEEP YOUR SHOULDERS LEVEL TO THE GROUND TO PROVIDE FOR EVEN LINE DEPLOYMENT.** This procedure should be practiced on the ground until you are comfortable and automatic with it. Additionally, with a friend to hold the pull-out handle, practice losing the handle and relocating it while laying on your chest. Have the friend hold the handle so as to simulate where it might be trailing behind you out of its retainers. It could be anywhere so have the friend move it through its complete range of travel while you locate it. The procedure for locating the handle is simple. With your left hand on the reserve ripcord and your eyes on the ground, reach behind you to the center of the main container and trace the lanyard from the closing pin to the handle, grip it and pull as described above.

THROW-OUT

To learn the use of a throw-out lay on your chest in a skydiving arch with the rig on. Locate the plastic cylindrical handle at the top of the right leg pad with your right hand while your left hand compensates for level fall. Don't bother to look for the handle. You probably can't see it and you should be looking at traffic and altitude in an actual skydive. Grip the handle and extract the pilot chute from its pouch and toss it vigorously into the air stream beside your body. Then look up over your head to watch the deployment. As you look up your body will come to vertical placing you in a sitting position for the opening. You must not allow the pilot chute to be released in front of your arm as that will wrap the bridle around your arm. Make sure that the pilot chute is released between your body and your arm. To assure that this occurs release the pilot chute before you look up. **KEEP YOUR SHOULDERS LEVEL TO THE GROUND TO PROVIDE FOR EVEN LINE DEPLOYMENT.**

RIPCORD

Lay on your chest on a flat surface and assume a skydiving arch. Without breaking the arch look down at the handle and insert the thumb of your right hand into the loop of the handle while compensating for level fall with your left hand. Thrust your arm forward and down then look up over your head to observe the deployment. Be sure to hold on to the handle as they are expensive and could hurt someone on the ground if you drop it.

CUTAWAY ACTIVATION

This familiarization should take place in a suspended harness. Locate the red pillow type handle on your right main lift web below your chest strap. Peel the handle off the velcro and thrust the handle down and away.

Students using the “Stevens System” should keep their head forward and down to prevent the cross connector from hitting their head, additionally they should select helmets that do not have a “snagable” edge which might catch a suspension line, riser, or cross connector.

You might want to locate and grip your reserve handle before activating the cutaway but don't take it out of the pocket until your main has released.

Students should be additionally trained to release both sides of the cross connector, from the main risers, upon confirmation of a fully inflated and functioning canopy over their head. That canopy will hopefully be the main. However, if an AAD misfire occurred at precisely the wrong moment or the reserve were activated in any manner at that critical time, it could be the reserve canopy. By deactivating the cross connector, the main, which would be inflated and trailing behind the reserve, could be cutaway safely. This

deactivation procedure would also prepare the main for cutaway, during ground drag, after landing.

RESERVE ACTIVATION

In a skydiving arch, with your chest on a flat surface locate the metal handle on your left main lift web below the chest strap. Insert your left thumb into the bottom curve of the handle while simultaneously gripping the vertical portion of the handle with your right hand. With both hands thrust down and away to the limit of your reach. You might want to leave your elbows extended as much as possible during the gripping phase, while looking up to keep from going head down. Experienced jumpers can bring their knees up for some additional compensation but newer jumpers must be cautious with this maneuver, it can cause a back loop. Pulling the reserve ripcord should be additionally practiced while in the suspended harness. A good time to practice both the cutaway and reserve pull is at the end of the certification cycle. The reserve must be inspected every 120 days, and that is a good time to experience how much effort is required to operate the handles of your SST.

**Now that you've thoroughly read the book,
we suggest seeing the movie - on video!**

It is available for \$25.00 from the Jump Shack. We consider it to be an essential tool in any riggers kit. For that matter it is an excellent learning aid for anyone who owns an SST, Racer, Elite™, or TRAINER.

Learn to “PRO PACK!”.

