

**UNITED PARACHUTE TECHNOLOGIES**

**VECTOR**

**SKYHOOK**



**SIGMA**



# OWNER'S MANUAL

# CONTENTS

**WARNING**

**DISCLAIMER - NO WARRANTY**

**A WORD FROM THE OWNER**

**CONTACT INFORMATION**

**MUTANT HARNESS AND CONTAINER SYSTEM**

**HOW TO SET IT UP**

**SETTING UP THE BALANCE**

**ADJUSTING THE HARNESS**

**CUTTING THE CABLES**

**INITIATING FLIGHT MODE**

**PRACTICE THE CUTAWAY PROCEDURE**

**SETTING UP THE CANOPY BEFORE JUMPING**

**GETTING READY TO JUMP**

**BEFORE EXITING THE PLANE**

**FIRST JUMPS**

**IN FLIGHT**

**FOR LANDING APPROACH AND HIGH-SPEED TURNS**

**EMERGENCY PROCEDURE NOTES**

**FINAL NOTES**

# WARNING

Use of this equipment in the United States and its territories should be in accordance with all USPA Basic Safety Requirement's (BSR's) included within USPA Skydivers Information manual (SIM), Section 2: Basic Safety Requirements and Waivers.

Use of this equipment outside of the United States should be in accordance with the controlling body for parachuting and skydiving in the country in which the equipment will be used & operated.

If you use your Vector 3, or if you allow someone else to use it, you are acknowledging sport parachuting risk and accepting the fact that the Vector 3 and its components may malfunction. If you are not willing to accept the risks of sport parachuting, or if you are not willing to accept the possibility that your Vector 3 or its components may malfunction and perhaps cause you to be injured or killed, then you may return your Vector 3 for a full refund before it is used. Details on how to do this are printed below.

# DISCLAIMER - NO WARRANTY

Because of the unavoidable danger associated with the use of this harness and container assembly, the manufacturer (Uninsured United Parachute Technologies, LLC) makes no warranty, either expressed or implied. This rig is sold with all faults and without any warranty of fitness for any purpose. The manufacturer also disclaims any liability in tort for damages, direct or consequential, including personal injuries, resulting from a malfunction or from a defect in design, material, workmanship or manufacturing whether caused by negligence on the part of the manufacturer or otherwise. By using this rig, or allowing it to be used by others, the buyer waives any liability for personal injuries or other damages arising from such use.

If the buyer declines to waive liability on the part of the manufacturer, buyer may obtain a full refund on the purchase price by returning the parachute harness and container, before it is used, to the manufacturer within 30 days from the date of original purchase with a letter stating why it was returned.

Take note that neon and fluorescent colored fabrics and tapes fade rapidly. Color brilliance may be lost within a year of manufacture. Uninsured United Parachute Technologies, LLC assumes no responsibility for this action.

Save this manual, your rigger may not have an applicable manual and will need it to service your Vector 3. This manual does not cover the correct assembly and packing procedures for the older Vector models.

Copyright © 1984-2015, Uninsured United Parachute Technologies LLC. All rights reserved.

# A WORD FROM THE OWNER

Dear Skydiver,

Congratulations on your purchase of a Vector 3 harness and container system - without question one of the safest and most reliable container systems on the market today. I have spent my entire skydiving career personally striving to improve the safety in our sport through various innovations and design ideas which are now incorporated into United Parachute Technologies products. From the 3-Ring release system, the hand-deploy pilot chute, the Booth ball reserve pilot chute, the first ever riser covers. The list goes on, and will continue to go on, as we develop the next generation of Vectors. You will find that most other container manufacturers have now incorporated these innovations into their own designs, following the lead of United Parachute Technologies.

Here at the United Parachute Technologies, LLC, we are totally committed to you, our customer, through the quality and performance in the harness and container systems we design, build and deliver. We stand behind our products 100% from the day it leaves our factory and reaches your doorstep, and have done so for over 30 years. You will find our service after the sale to be as comprehensive as our customers have come to expect from United Parachute Technologies. When you buy a Vector, you're buying more than a container system; you're buying innovation, quality, reliability, and most of all a product that has survived the test of time. United Parachute Technologies has built more sport, student and tandem harness/container systems than anyone else in the world. We've been here for over 3 decades, designing the equipment that meets the imagination of today's skydiver.

Thank you again for your purchase of a Vector - with proper care and maintenance it should provide you with many years of safe and enjoyable skydiving. Should you have any questions or concerns about your equipment, please do not hesitate to contact us.

Blue skies!

Bill Booth  
President, United Parachute Technologies, LLC





# CONTACT INFORMATION

If you have any questions, comments or suggestions after reading this manual, please feel free to contact us. United Parachute Technologies is open **Monday** through **Thursday**, from **8 am to 5 pm** EST, Friday **8 am to 12 pm** EST.



United Parachute  
Technologies  
1645 Lexington Avenue  
DeLand, FL 32724-2106  
USA



P: +1 386 736  
7589  
F: +1 386 734 7537  
RIGGING LOFT:  
P: +1 386 736 7471



[WWW.UPTVECTOR.COM](http://WWW.UPTVECTOR.COM)



[UPT@UPTVECTOR.COM](mailto:UPT@UPTVECTOR.COM)

# MANUAL REVISION HISTORY

REVISION	DATE	AUTHOR	DESCRIPTION

# MUTANT HARNESS AND CONTAINER SYSTEM



The Mutant Harness & Container system is comprised of the following items:

1. Mutant Swoop container & harness
2. Swoop mode release handle & cable
3. Main pilot chute
4. Main deployment bag
5. Mutant Swoop main risers
6. Cutaway handle
7. Reserve handle
8. Reserve pilot chute
9. Reserve deployment bag
10. Reserve risers
11. Large "Jack Knife" hook knife & pocket

Please refer to Vector 3 manual for details on other components that are not unique to the Mutant Swoop system.

Cable Cutter - Use for trimming the cut away cables.

Pliers - Use to help with adjusting the webbing. Make sure there are no sharp edges or wrap with tape to keep from damaging the webbing.

Flat head screwdriver - Could be used to help ease the webbing if it's tight.

Measuring tape.

White chalk or a tailor's pen.

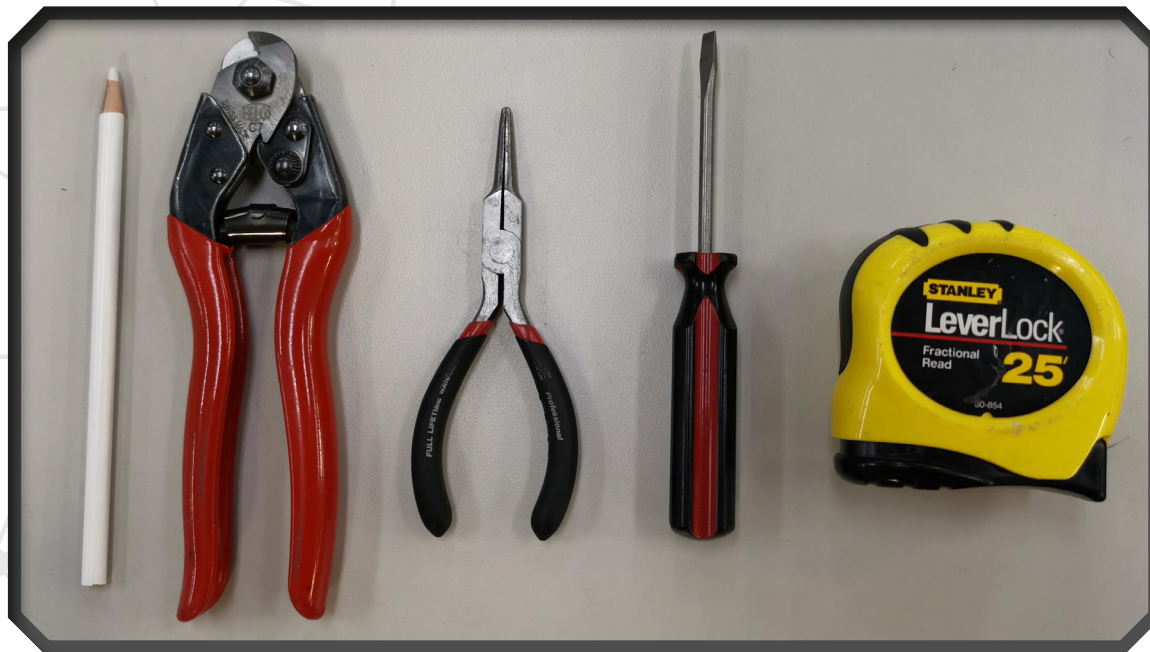



# HOW TO SET IT UP

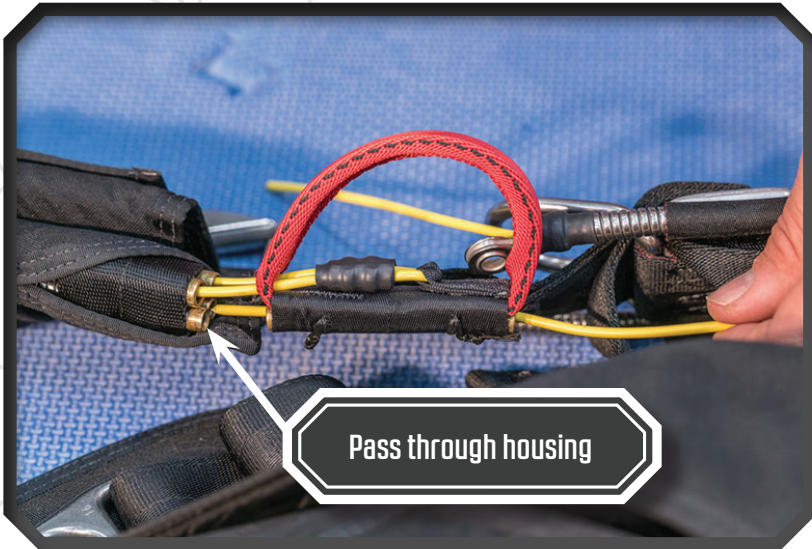

Install the sloop mode release cable through the housing which is part of the Red Cutaway Handle.

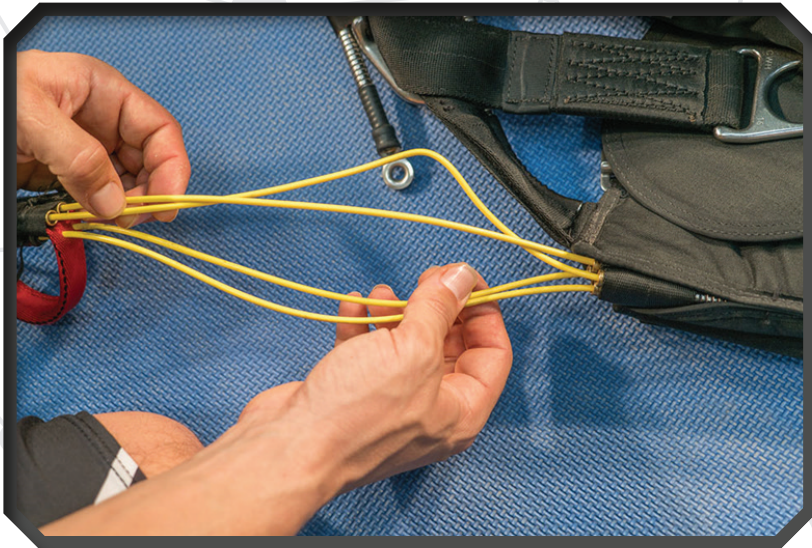

All cables should be properly lubricated with silicon.



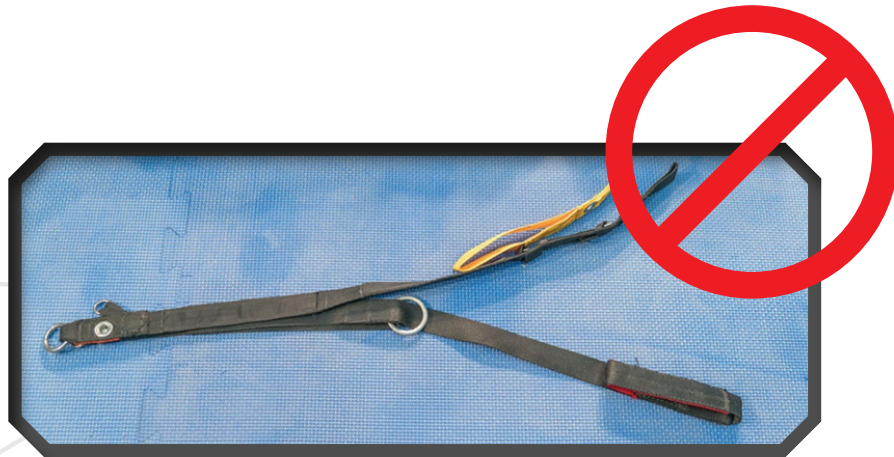

Before installing the main risers, the rear riser leg must pass through the ring that will connect to the upper attachment point on the harness.





Set up the lower attachment points first. The main risers are attached to the lower harness attachment ring following the same method for typical 3-ring assembly.





# SETTING UP THE BALANCE



At this point, you only need to have the bottom 3-rings attached.

It is extremely important to have the system adjusted properly for the pilot.

The best way to do this is by suspending the harness and container system. This will allow you to set up the correct balance for flight mode and practice with the cutaway system.

Any type of set up for suspending the harness can be used.





Get into the harness and begin adjusting as seen in the following photos. It's important to understand that the leg straps do not need to be as tight as normally seen on a conventional Vector. This will improve the comfort when in flight mode.

The chest strap is also adjusted keeping in mind it does not need to be as tight as normal. It should also be noted that the chest strap will stay on when in Flight mode.





# ADJUSTING THE HARNESS

*\*The reserve canopy must be assembled and packed to properly fit and adjust the system.*

There are three adjustment points to set up for flight mode.

- **Main lift web**
- **Lateral back strap**
- **Belly band**

The ideal body position needed relative to the main risers is approximately 45 degrees. When relaxed with your hands on the risers, you should not have to put any effort to pull your chest forward. You should also be able to sit back comfortably.

We recommend using some tools to help out with the adjustments. See page 7 to for a list of tools.

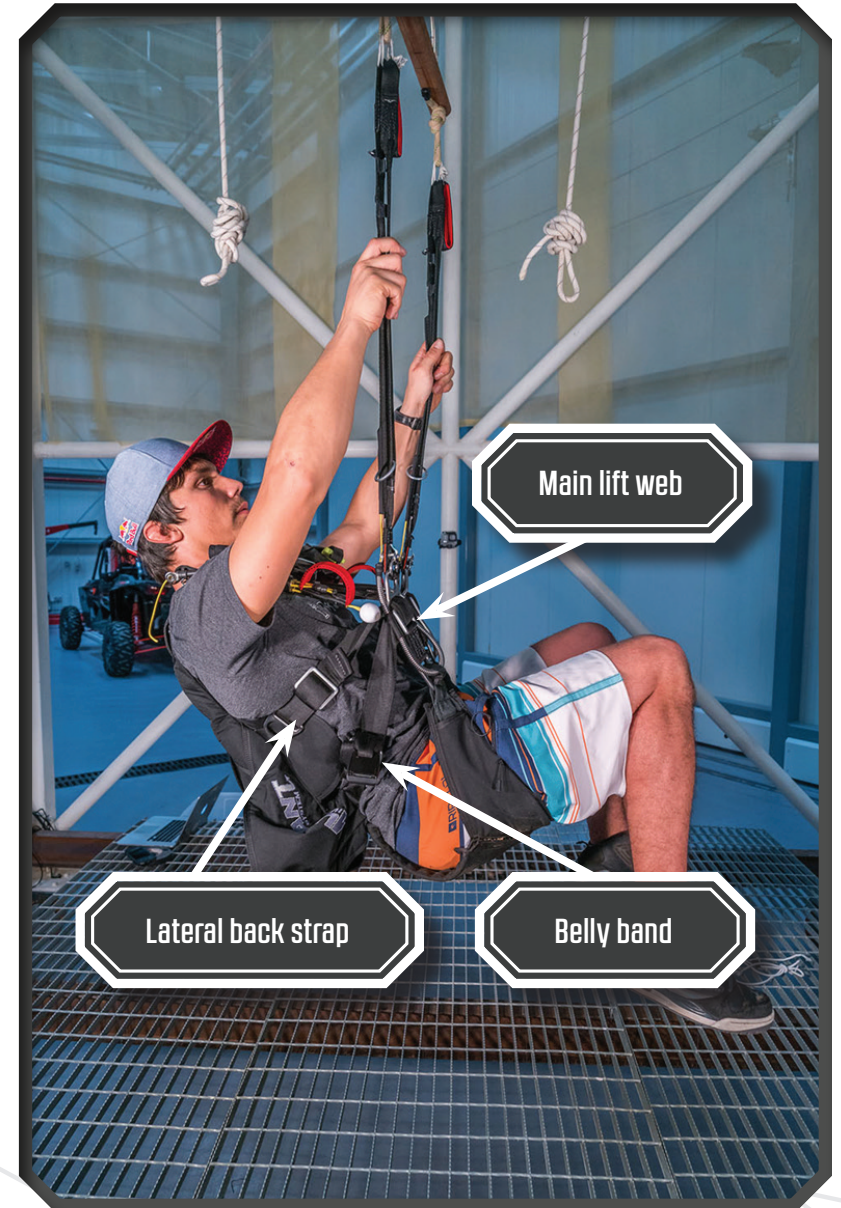

*\*The following adjustments should be made as needed. To make for easier adjusting, have the pilot get in and out of the system or have them stand up, so that there is no tension on the webbing. Ensure both lateral straps are even on both sides.*

If you are sitting too far back, shorten the main lift web followed then by the lateral back strap.



If you are sitting too far forward, lengthen the main lift web followed then by the lateral back strap.



If you feel pressure on your lower back, extend the BACK part of the belly band to enable you to move back.

Once the lateral back straps appear correct, adjust the belly band utilizing side adjustments to support the desired pilot angle.

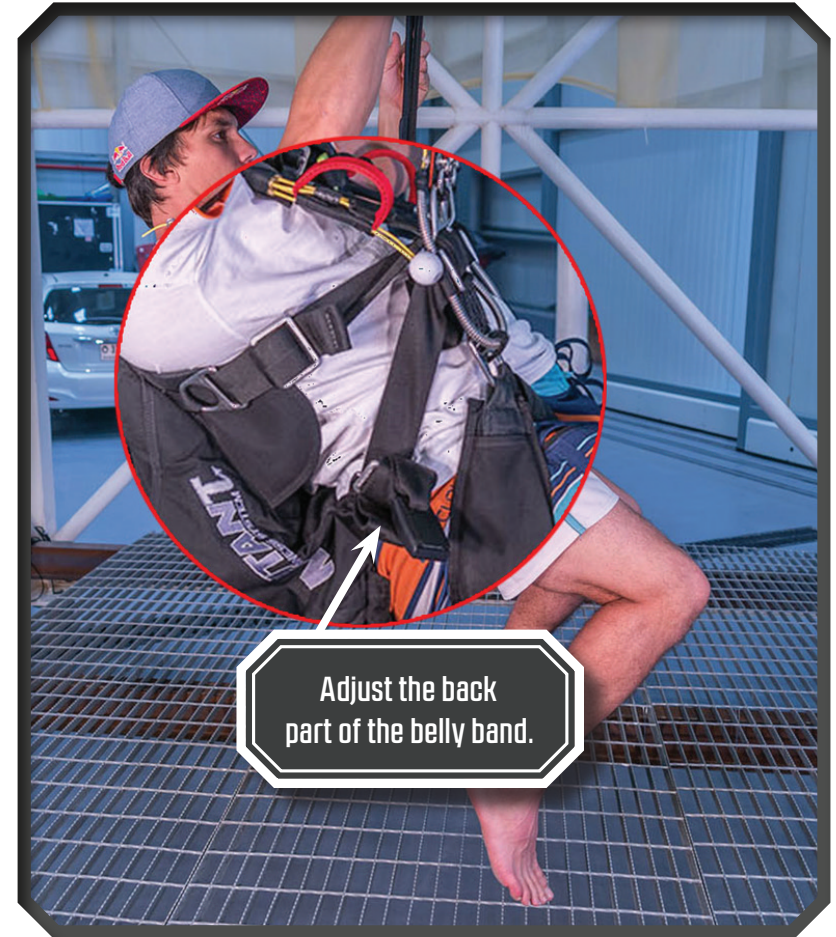

Adjust the back part of the belly band.

After the pilot's angle is established, have the client stand up and utilize center adjustments to ensure a comfortable fit and centered position of the belly band's release mechanism.

The ideal position may vary for every person. For the example shown here, the body is shown relaxed at approximately 45 degrees. When the leg straps are pulled forward the jumper can sit back as shown.



Practice how to balance yourself in the harness by lifting your right leg to shift the balance.



Do the same for the opposite side.





Practice the sequence of standing up for landing.



When you feel you have found an ideal position the harness should be marked at ALL adjustments locations. Mark both sides making sure they are symmetrical.

Marking the harness gives a baseline to work with. You may need to make small adjustments after a couple of jumps.

When making marks, be sure to only use chalk or a tailor's pencil.



Mark at these locations.



Once in the harness with leg straps and chest strap adjusted, the belly band can't be adjusted. First, close the seat belt adapter. If the belly band is too tight or too loose, undo it and adjust the 3-bar adapters accordingly. Do the seat belt clips up again and check the adjustment. Once the belly band is set, it should not need further adjustment. The fitting of the belly band will change slightly with the main container packed.



With everything adjusted and secure, you are now ready to hang in the harness.

# CUTTING THE CABLES

*\*This will require both top and bottom attachments to be set up.*

Make sure there are no twists before connecting the main risers to the top attachment ring.

Connect the top ring to the risers.

Make sure the cable for the connection is routed correctly. The cable must pass through the ring and into the housing.

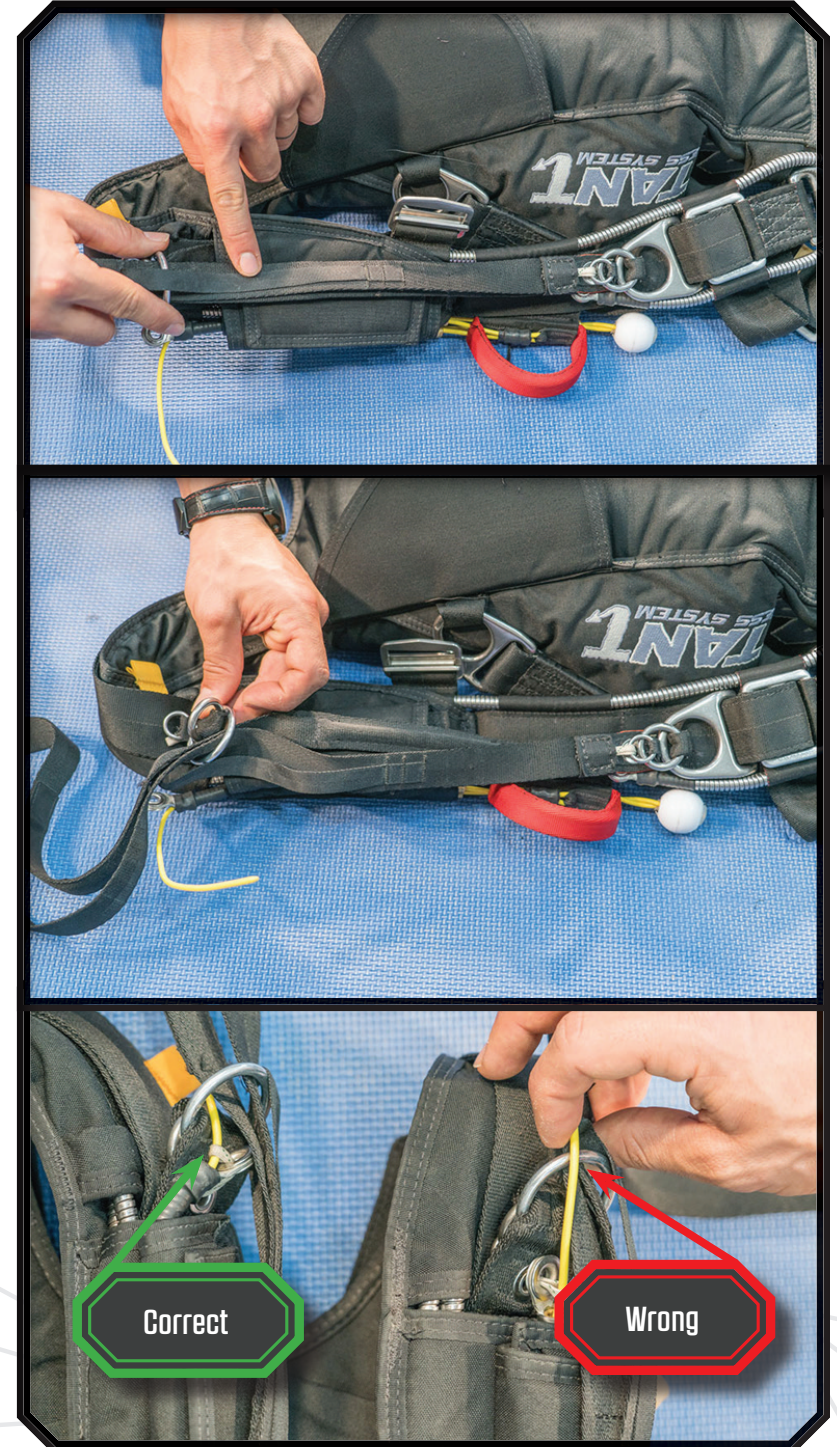



Make sure you are not touching the ground for this test. Try to feel the difference compared to your normal rig. You can see and feel that the top attachment point is just a guide and the load is taken on the lower attachment point.





- Connect upper riser ring attachment point according to the manual, assuring proper riser alignment under the riser covers and that there's proper routing of the cutaway cable through the upper ring.
- Demonstrate full closure of the riser covers for freefall, and partial closure, using just the magnets for hop&pops.
- With pilot hanging, ensure all cutaway housings are at full length and all slack equalized.
- Initiate a slow pull, we want to ensure the top rings release first. If cable length is excessive, trim length only with respect to ability to stow excess in the back of the riser. Make marks before any cutting to be sure all is correct.
- Release loading by having client stand, check marks and housing lengths.
- Reseat the housings and perform another slow cutaway. Note whether marks are correct or adjust if necessary. Cut top cables.
- Add 4cm to mark at the bottom release cables, to ensure the top release first.
- Perform a full cutaway at normal speed of operation to ensure a smooth and symmetric release.

While hanging in the harness, you will see that the release cable is too long and needs to be trimmed. Use the following method.

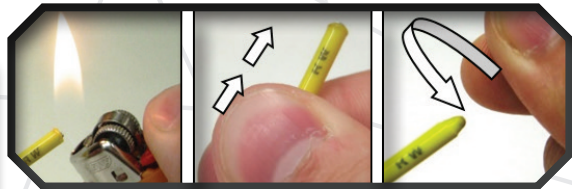

Heat only the tip with a lighter until it just begins to mushroom. Quickly and firmly grasp the cable just below the heated end. In one smooth and fluent motion, quickly and repeatedly pull the firmly gripped cable completely out rotating it 90° each time. Reheating up to 3 times may be necessary.



# INITIATING FLIGHT MODE

*\*Connect both, bottom and top attachment points.*



Release the top attachment point by pulling the white ball handle.



Do not pull it all the way, just enough to release the 3-ring assembly on each side.



Close-up view of the cable out of the loop.



There is no load at the rings so you may have to push back a little to release them.

If you need to cut away, the load will be created by the release of the bottom ring. You will see it on the full cut away test coming in the next chapter.





Push back to release upper attachment if needed.

Push the cable back into the housing to keep it safe and out of the way.



Push back in





Release the belly band.

Use both thumbs to slide the leg straps forward allowing you to sit back.





# PRACTICE THE CUTAWAY PROCEDURE

Practice the full cutaway procedure to get familiar on this system. The lower release handle (white ball) is connected to the RED cutaway handle. When the red cutaway handle is pulled it will also disconnect the lower attachment points.

For the first practice cutaway, reconnect the top rings and close the belly band to simulate a cutaway that directly follows main deployment.

Be sure to practice the cut away procedure multiple times, from both deployment and flight modes.

***When cutting away, be sure to realize that both the cut away and reserve deployment handles are not in the same location of a normal rig. When cutting away, be sure to pull the handle down and not forward. Pulling forward could create an angle with the cable housing and increase the pull force.***



To avoid injury, make sure you have a soft surface underneath before performing this procedure.

You should be able to pull the handle with only the thumb. If you feel too much resistance, make sure you have lubricated all cables correctly.

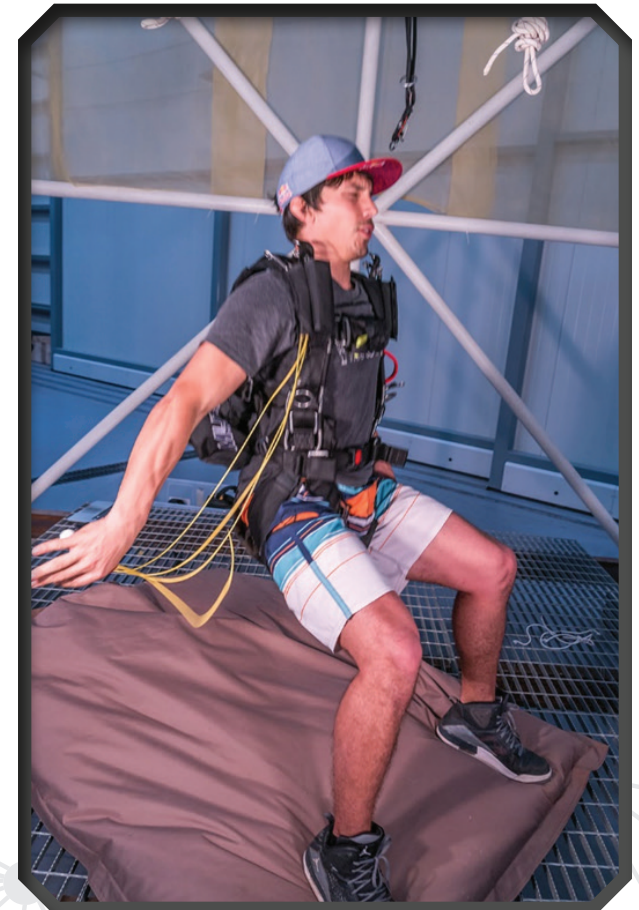
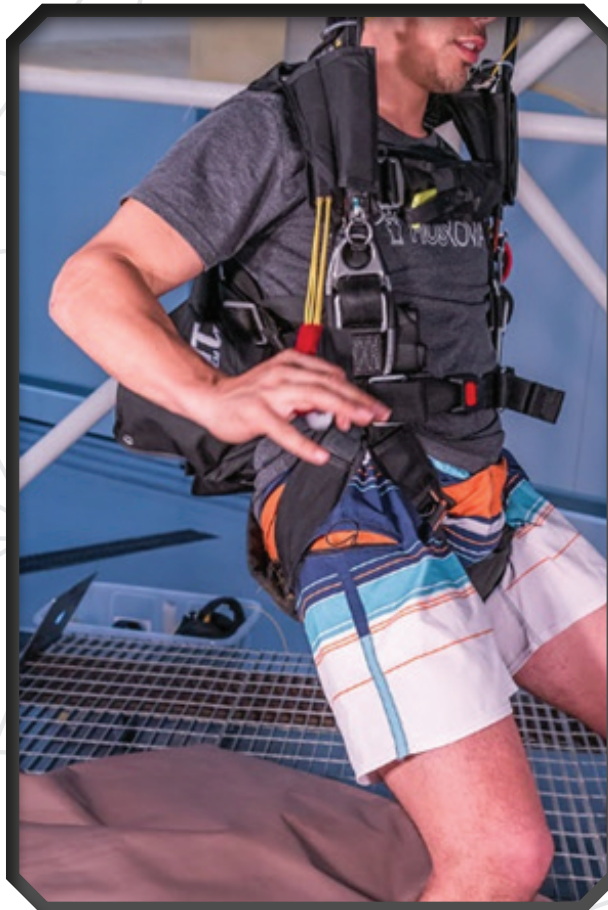



# SETTING UP THE CANOPY BEFORE JUMPING



Setup the main risers using the canopy you will jump in the beginning. It's recommended that you start off with a more lightly loaded and less aggressive wing than what you normally use.

As you noticed when you were hanging, the load on opening is on the low attachment point, which makes it more sensitive in-flight mode as well as during the opening. It's better to have a larger canopy for the first jumps to test the full system so you have no surprises.

***You must use a removable slider with the Mutant.***

Make sure the main risers are not twisted, place them nice and flat along the reserve.







Close the internal riser cover followed by the external riser covers.

The magnetic riser covers will be properly closed at a later step.

Close both sides of the container.





Continue closing the main container following the typical Vector 3 method.



Now that the container is fully closed, you can close the front riser cover.

*Pay attention not to put the chest strap around the risers. It can happen.*

Close the front riser covers for hop & pop jump.

Close front riser cover fully for freefall jump.





Close the top magnetic external riser covers following typical method for the Vector 3 container.



# GETTING READY TO JUMP



Jumping with the Mutant system should be taken seriously. The equipment should be checked before every jump and we encourage practicing emergency procedures routinely



## *Check list*

- White ball is pushed in.
- Upper attachment point is connected and cable is inside the housing.
- Front riser cover in place.
- Hook knife attached.
- Belly band is not twisted and closed.



# BEFORE EXITING THE PLANE



Last checks in the aircraft.

Be sure the white ball is in the proper position and seated against and hasn't moved down behind the lateral webbing.

Do a proper 3-ring check.

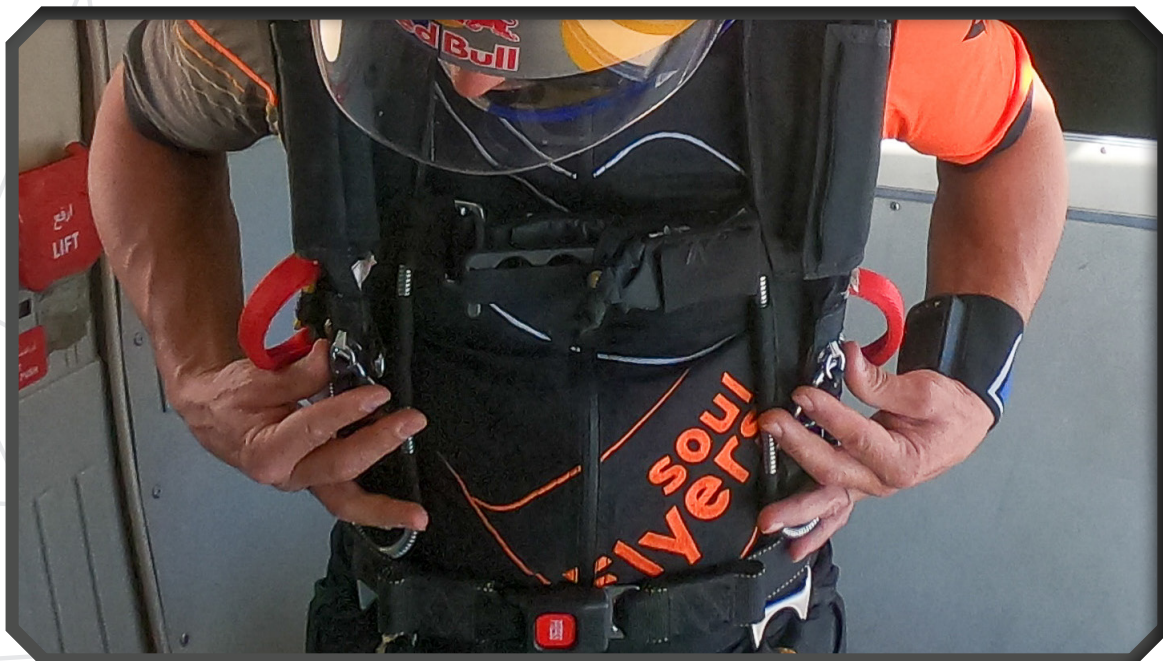





Check your front riser covers, top attachment, and make sure the cut away cable is in the proper position.





Finally, make sure your belly band is properly closed.

***DO NOT FORGET THIS STEP!***



# FIRST JUMPS



Exit the aircraft with a normal hop & pop deployment. No back flips or other complex maneuvers.

During canopy deployment, check to make sure you are stable.

Canopy is open and flying.

Remove and stow the slider.





Release the top attachment point.



Push back the ball when the top part has released.



Undo the belly band.



Push the leg straps forward to allow you to fully sit back.



Take your toggles and fly!!



# IN FLIGHT

For turns, the hip inputs are much more effective at creating powerful, radical turns.

Standing up and leaning forward on both risers makes the canopy dive, so we don't need to use the front risers to start the turn. Therefore, by not using the front risers and changing the canopy's shape it results in getting better swoop performances.

Sitting back makes the canopy glide. For the landing, the recovery arch can be done partly just by sitting back, and almost not using the back risers. So, by not using the brakes or rear risers and changing the canopy's shape, it yet again results in a better swoop performance.

## FOR LANDING APPROACH AND HIGH-SPEED TURNS

It is very important to take this maneuver step by step, because of the way you are sitting and flying in the Mutant harness, the visual references are very different. If you stand up, the canopy dives much more so don't try to hit the gates on the first landing. Be respectful of the potential airspeed of this system, and the differences from your normal canopy... we suggest taking a more conservative approach than normal, until familiarity is gained.

## EMERGENCY PROCEDURE NOTES

The emergency procedure is the same as with a normal Vector container. The difference is you will cut away 4 points instead of 2 - the lower and the top attachment. It is important to remember to not wait too long to make the decision to cutaway. If you open and you have line twists, do not waste lots of time fighting it, cutaway and make sure you pull the handle all the way to release all attachment points. Stabilize and pull your reserve handle as normal.

If you cut away, and the canopy is still attached at one of the attachment points, make sure you have pulled the handle completely including the white ball. Pulling the white ball will only release the upper attachment points.

If nothing changes use your hook knife to cut free from the malfunctioning canopy.

When flying under a reserve canopy and you have time, try to close the belly band before landing. This will simply improve comfort for landing. If there is limited time proceed to land.

If you end up pulling low and you don't have time to go in to flight mode, don't open the belly band, and land with the top attachment point unreleased, it's fine to land like that, I have done it as well.

# FINAL NOTES

After enough jumps, when you feel comfortable with the position under canopy, you can go and see your rigger and have them stitch the belly band and the lateral webbing based on your chalk marks. You can take note of your final measurements on the following page.





NAME:
DATE:
SNR:
V:3 _ _
DOM:

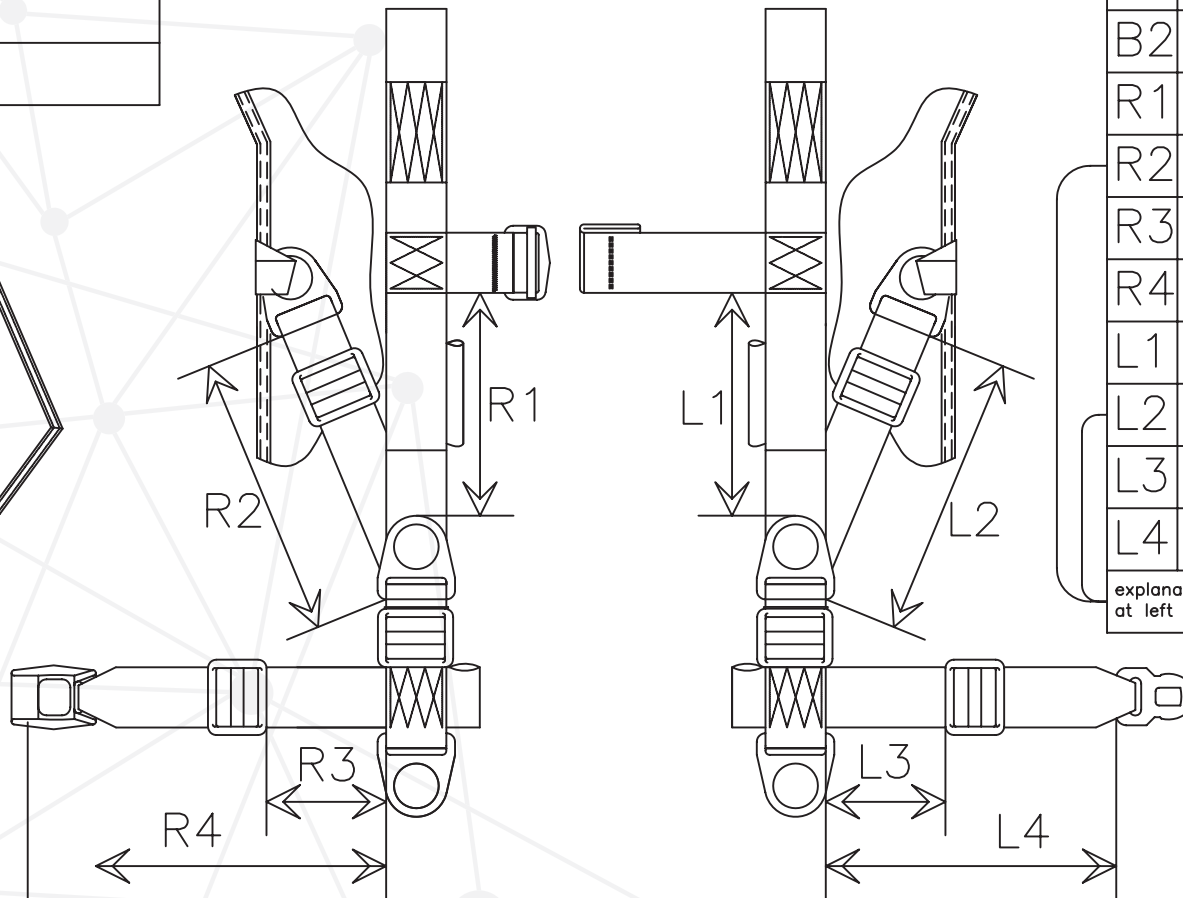
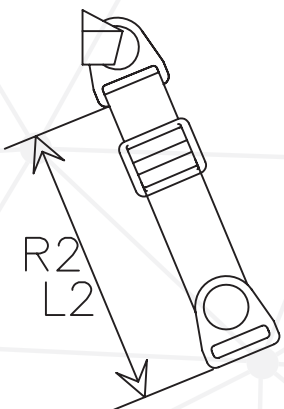
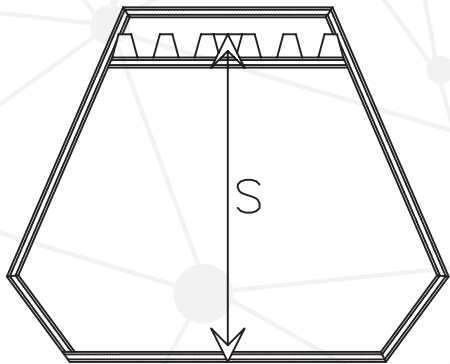
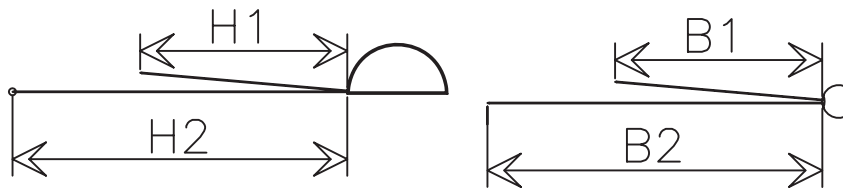

S	
H1	
H2	
B1	
B2	
R1	
R2	
R3	
R4	
L1	
L2	
L3	
L4	
explanation of measurement look at left bottom of page	