

Javelin Legacy Owner's Manual

Also applies to all harness/container systems
manufactured before Feb 2007

JAVELIN™
Odyssey

JAVELIN™
JAVELIN™



**Manufacturing
Skydiving Equipment
Since 1987**



Made with pride in
Raeford, NC, USA



SERIAL # _____

CONTAINER SIZE _____

YOKE _____

HARNESS _____

LATERAL _____

LEGPAD _____

P.O. # _____



404 W Edinborough Avenue
Raeford, NC 28376 USA
Tel +1 910 875-9002
Fax +1 910 875-9272
www.sunpath.com

JAVELIN OWNERS MANUAL

TABLE OF CONTENTS

WARNING..... 4

INTRODUCTION..... 5

PARTS LIST..... 6

MAIN PACKING INSTRUCTIONS..... 7

KILL LINE INSTRUCTIONS..... 10

THROW-OUT PILOT CHUTE PACKING INSTRUCTIONS..... 11

PULL-OUT CHUTE PACKING INSTRUCTIONS..... 17

RAM-AIR RESERVE PACKING INSTRUCTIONS..... 19

ROUND RESERVE PACKING INSTRUCTIONS..... 25

RESERVE STATIC LINE (RSL)..... 31

3-RING RELEASE..... 33

REQUIRED PERIODIC MAINTENANCE FOR THE 3-RING..... 36

BEFORE USING THE JAVELIN..... 37

DONNING THE JAVELIN..... 38

MAIN DEPLOYMENT..... 39

RESERVE DEPLOYMENT(PARTIAL MALFUNCTION)..... 39

RESERVE DEPLOYMENT (TOTAL MALFUNCTION)..... 40

COPYRIGHT 1987, 1988; SUN PATH PRODUCTS INCORPORATED. ALL RIGHTS RESERVED

404 W Edinborough Avenue, Raeford, NC 28376 USA • Tel +1 910 875-9002 • Fax +1 910 875-9272 • www.sunpath.com



The purpose of this manual is to acquaint the rigger and prospective user with the functions, packing procedures and other features of the JAVELIN harness/container system. It is NOT intended to be a course in parachute jumping. This manual should be read and understood by anyone who intends to use a JAVELIN system for sport parachuting, however, it is the responsibility of the owner to be sure that the JAVELIN is correctly assembled, packed, maintained and used. It is also the jumper's own responsibility to assure that he is qualified for participation in sport parachuting activities. (Any gender references automatically refers to the user)

For more information on the Javelin Harness & Container System and general information about Sun Path Products, Inc. please check out our web site at <http://www.sunpath.com>

!!! WARNING !!!

Parachuting is a hazardous activity and there are dangers which sometimes cannot be foreseen. No one should attempt to make a parachute jump unless they have been thoroughly trained by an experienced and qualified instructor. There are no guarantees that any equipment will function as intended, regardless of how it is assembled, packed, maintained or used. Serious injury or death can result from the use, misuse, or attempted use of any parachute equipment.

!!! THE USER ASSUMES ALL RISKS !!!



INTRODUCTION

The JAVELIN and JAVELIN Odyssey is a sport parachute harness/container system featuring back mounted main and reserve canopy containers. The reserve container is characterized by the partially exposed top plate of the reserve pilot chute, which is packed on top of the side flaps.

The JAVELIN is equipped with the 3-Ring release system under a license agreement with The Relative Workshop Incorporated. Other standard features include throw-out hand deployed main pilot chute, single-pin reserve closure, step-in leg straps and "wrap around" harness construction. This type of harness construction produces junctions which are not limited to the strength of the stitches. In the JAVELIN, the harness junctions are stronger than the webbing itself.

The JAVELIN Odyssey includes new features such as "Quilted look" Cut-in Backpad, Split legstraps, anti-twist riser tubes, new fabric options, housing clamps and large Odyssey logos on the main riser covers.

The reserve container will accept either a round or ram-air reserve canopy. For ram-air reserves, the JAVELIN is supplied with the unique "MOLAR-BAG", a free-bag which features zero thickness where the closing loop passes through it, eliminating the need for any preliminary fid or preliminary pull-up cord when packing the canopy into it. This also prevents any of the canopy fabric from coming into contact with the closing loop.

Design and testing of the JAVELIN was accomplished over a period of eighteen months and has resulted in one of the most "RIGGER FRIENDLY" systems on the market. There is no additional sewing or tacking required to assemble the JAVELIN with canopies and no "special techniques" are necessary to pack it. An FAA certified rigger with current skills should be able to assemble and pack the JAVELIN by following the instructions in this manual.

The JAVELIN harness/container system was tested in accordance with AS-8015A and is approved by the FAA under TSO C-23c, Category B.

In October 2001 the Javelin harness/container was retested in accordance with AS-8015B and is approved under TSO C-23d for:
a maximum operating exit weight of 300lbs (136 kg) and
a maximum operating speed of 170 knots (198 mph or 330 kph).



PARTS LIST

Congratulations on your new rig! Your Javelin Legacy was shipped to you with the following components: (please inventory your system before assembly)

1. Harness/Container
2. Main risers with control toggles
3. Main deployment bag
4. Release/cutaway handle ^(a)
5. Main pilot chute w/kill line bridle
6. Reserve spring loaded pilot chute ^(b)
7. Reserve "molar" style freebag w/bridle ^(c)
8. Reserve ripcord with Terminal Pin
9. Reserve static line ^(d)
10. Reserve control toggles
11. Main closing loop
12. Reserve closing loop
13. Reserve pack date data card
14. Hook knife and pouch
15. Javelin Legacy owner's manual
16. Courtesy kit with pull up cord, sticker, rubber stow bands, and spare main closing loop

- a. Only emergency handles manufactured by Sun Path may be used with the Javelin Legacy
- b. Only reserve pilot chutes manufactured by Sun Path can be used with the Javelin Legacy
- c. Only the Sun Path "molar" style freebag may be used with the Javelin Legacy
- d. If the block "No RSL" was checked on the original order form this item will not be present.

All components listed above are available from Sun Path or any of our authorized dealers.

Sun Path Products Inc.
404 W. Edinborough Ave
Raeford NC 28376 USA
+1 910 875 9002
www.sunpath.com or info@sunpath.com





MAIN PACKING INSTRUCTIONS

This chapter deals with the procedures for packing the a ram-air main canopy into the JAVELIN harness/container system. Assembly and packing of the main must be done by an FAA certified rigger or by the person making the jump.

1. Carefully inspect the main canopy, suspension lines, control lines, slider and grommets, connector links, etc., before assembling it with the risers. Replace or repair any worn or damaged parts. Also inspect the deployment bag, bridle and pilot chute.

2. Attach the main canopy to the main risers, being sure that the canopy is facing the same direction as the harness/container system and that each suspension line is clear from its attachment point all the way through the slider grommet to the connector link without passing around any other line. Be sure the control lines are clear from the trailing edge of the canopy through the slider grommets and through the ring guides on the rear risers to the control toggles. Each control toggle must be **SECURELY** tied to its control line at the location specified by the canopy manufacturer. Also be sure that the connector links are tight enough so that they cannot be loosened with the fingers alone. Also refer to the canopy manufacturers owners manual.

3. Pass the pilot chute bridle down through the grommet in the top of the deployment bag and attach it to the ring on the top of the main canopy. Be sure that the stop-ring on the bridle is between the bag and the pilot chute.

For kill line attachment and cocking of the kill line pilot chute refer to instructions on page 10.



4. Set the deployment brakes on each side by pulling the control line down through the guide ring until the brake loop just passes through the guide ring (FIG. 1).

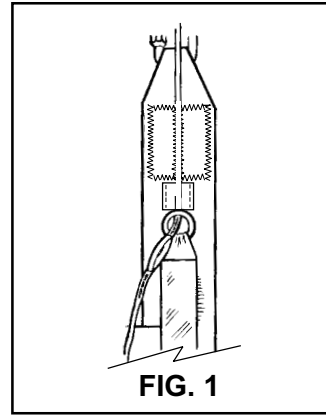

FIG. 1

Insert the stiffened upper portion of the toggle through the loop and insert the upper portion into the elastic keeper, pull the control line back up tightly against the guide ring. (FIG. 2).

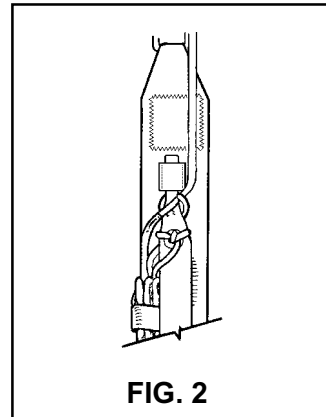

FIG. 2

FOR VELCRO TOGGLE

S fold the slack between the toggle and the brake set and stow it in the Velcro loop provided, then mate the Velcro on the riser.

FOR NO VELCRO TOGGLE

Next insert the stiffened lower portion of the toggle into the elastic keeper in the same direction as the top portion (from the bottom of the riser towards the top). (FIG. 3).

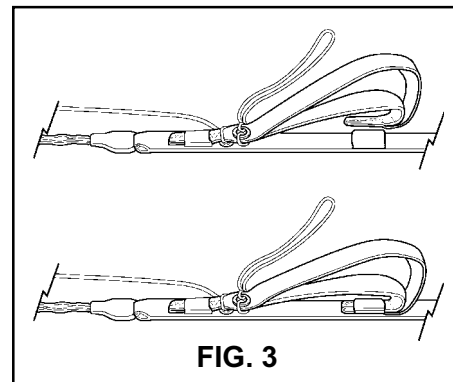

FIG. 3

5. At this point, refer to the directions by the canopy manufacturer for flaking and folding the canopy. After flaking and folding it should resemble (FIG. 4).

Be sure the slider is up as far as it will go against the canopy.

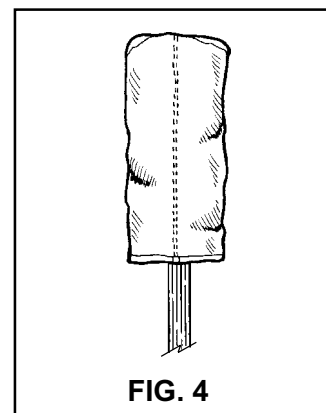

FIG. 4

**“Cock the Kill Line Pilot Chute”,
before placing the canopy in the main bag!**

Kill Line Instructions refer to page (10)

6. Stack the canopy in "S" folds as shown in (FIG. 4).

Keeping the slider up against the canopy and keeping the slack out of the lines. The stacked canopy should be 3-4 inches wider than the bag.

7. Pull the bag down onto the canopy. Try to fill the corners and sides of the bag to distribute the bulk evenly and avoid forming a lump in the middle.

8. Mate the locking stows with the suspension lines to close the mouth of the bag. Center locking stow, to be stowed first (FIG. 5).

During this part of the packing procedure always make sure that the rubber bands used for the locking stows are strong and in good condition. The weight of the canopy inside the bag comes to bear on these locking stows when the canopy is lifted off the jumper's back during deployment and a broken locking stow at this point may result in an out-of-sequence deployment.

9. Pull the bridle out from the top of the bag until the metal ring of the canopy is seated against the grommet of the bag. Be sure there is no canopy fabric between the ring and the grommet. Now stow the remainder of the suspension lines across the bottom of the bag in the rubber bands at each end. Make line stows as per canopy manufacturers recommended size/length. Leave 12" to 15" of lines unstowed between the bag and the connector links. (FIG. 6).

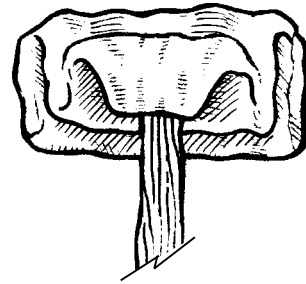

FIG. 4

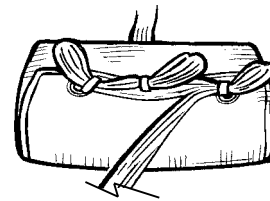

FIG. 5

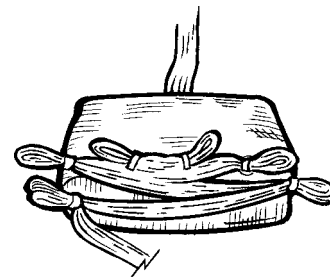

FIG. 6



10. Lay the risers in the "trough" between the sides of the reserve container and the riser covers. Don't wrap the lines and risers around reserve pack tray. Place the bag in the container with the line stows toward the bottom. This position is important; if the line stows are toward the top, it may be more difficult for the pilot chute to extract the bag (FIG. 7).

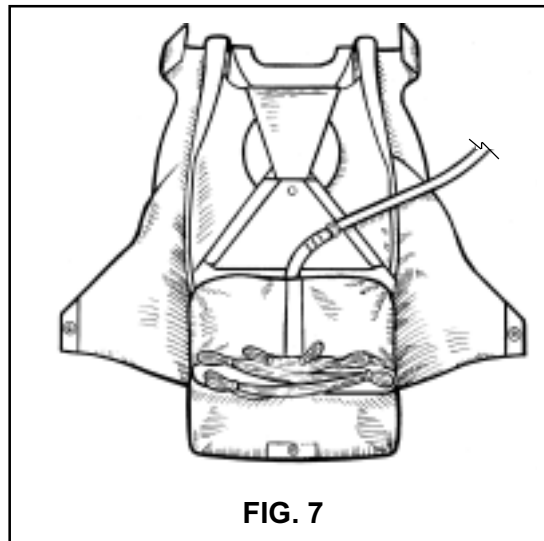

FIG. 7



FIG. 1

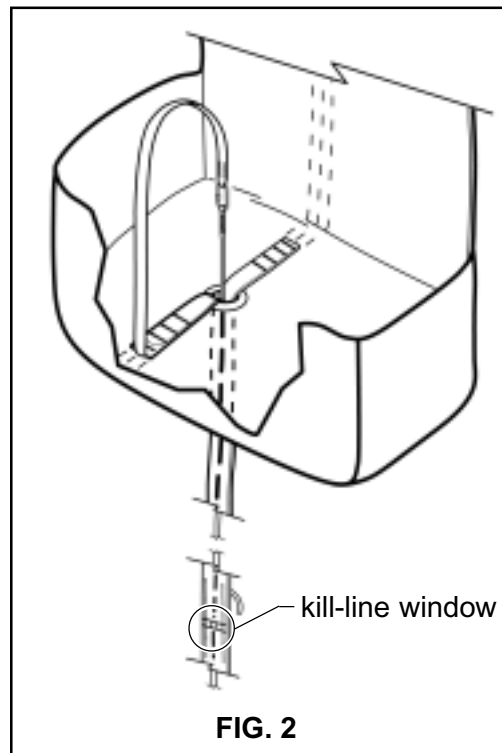

FIG. 2

KILL-LINE INSTRUCTIONS (Sun Path Products, Inc. does not recommend the use of zero-p pilot chutes)

The pilotchute should be "cocked" before placing the canopy into the deployment bag. To do this simply anchor the bag (your foot works great) and pull out on the pilotchute handle until the center line is tight (FIG. 1).

To double check that you have fully cocked the pilotchute, check to see that the green portion of the kill-line is visible in the window on the bridle (FIG. 2).



FOR JAVELINS EQUIPPED WITH A PULL-OUT PILOT CHUTE SKIP TO PAGE 17

JAVELINS EQUIPPED WITH A THROW-OUT PILOT CHUTE

11. Thread the pull-up cord through the closing loop and bring the closing loop over the top of the bag. The bridle should be routed to the right of the closing loop. Thread the pull-up cord through the bottom flap grommet and close the bottom flap (**FIG. 8**).

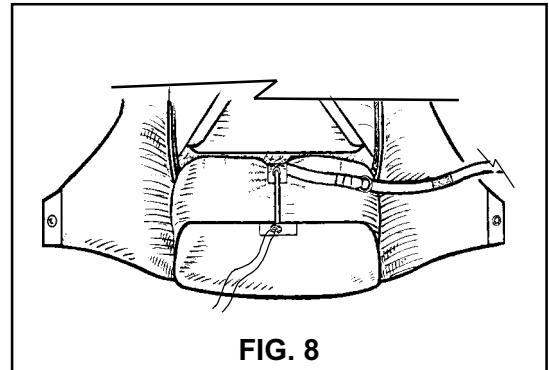

12. Close the top flap, keeping the bridle to the right (**FIG. 9**).

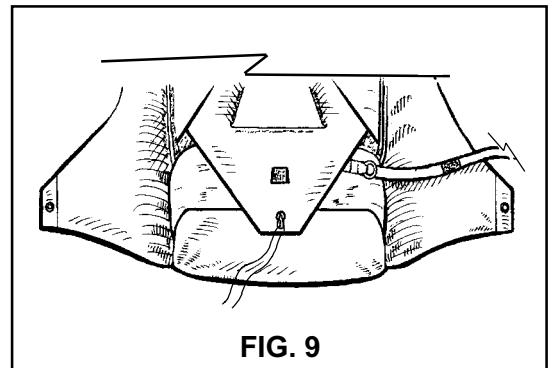

13. Mate the velcro on the bridle just above the curved pin, to the velcro on the top flap. Close the left side flap, then the right side flap, inserting the curved pin attached to the bridle into the closing loop. Remove the pull-up cord SLOWLY to avoid wearing the loop. This is very important: it assures that the pilot chute bridle will have sufficient slack to extract the curved pin (**FIG. 10**).

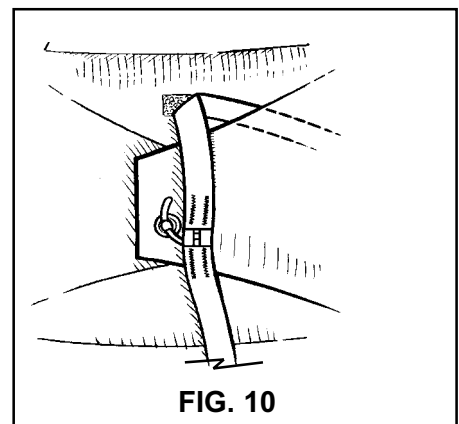

FOR JAVELINS EQUIPPED WITH A BOTTOM OF CONTAINER (BOC) THROW-OUT PILOT CHUTE SKIP TO PAGE 15

JAVELINS EQUIPPED WITH A REAR OF LEG (ROL) THROW-OUT PILOT CHUTE

14. Mate the velcro on the bridle to the velcro on the lower right side of the main container, harness-lateral and leg pad. The excess bridle between this velcro and the curved pin should now be tucked under the right side flap (**FIG. 11**).

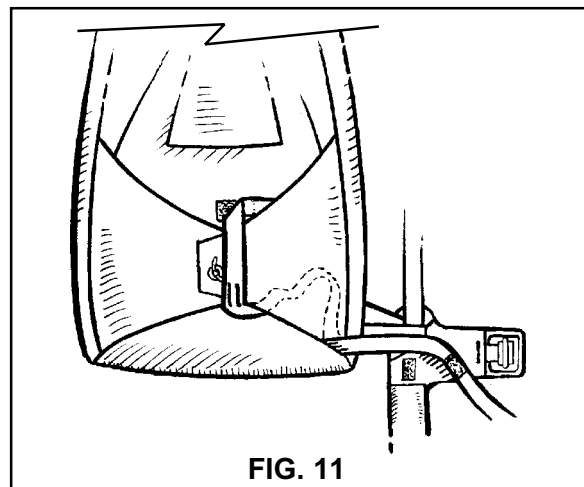

15. Close the top flap protector by tucking the "tongue" underneath the closed flaps (**FIG. 12**).

At this point be sure that the bridle goes from the container to the pilot chute without passing under or through any part of the harness. Bridle velcro to be mated to velcro along side of container.

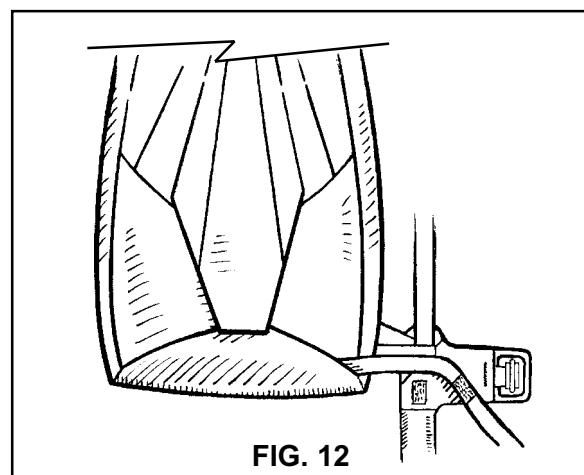

16. Lay the pilot chute out flat with the mesh side up. Fold the excess bridle on top of the laid out parachute and fold the pilot chute in half over the bridle (FIG. 13).

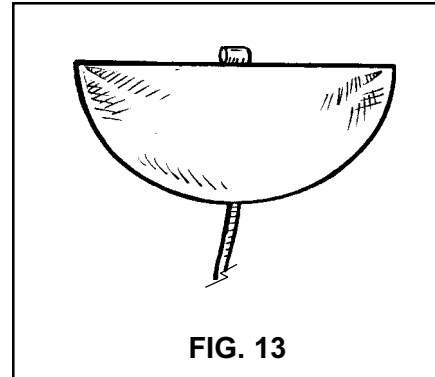

Fold the curved side up about 4" (FIG. 14).

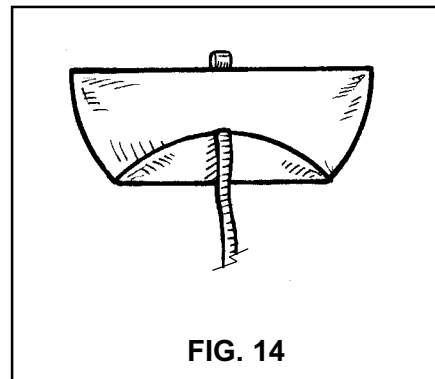

17. Fold the pilot chute into thirds (FIG. 15).

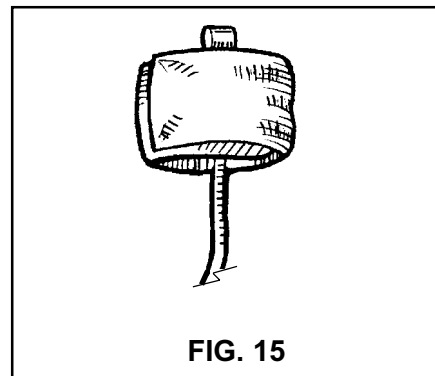

Roll it tightly into a cylindrical shape (the tighter the better) (FIG. 16).

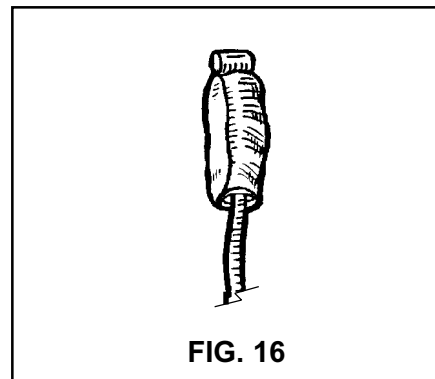

18. Stuff the rolled pilot chute completely into the pouch, making sure that the handle sticks out the top for an easy grip (FIG. 17).

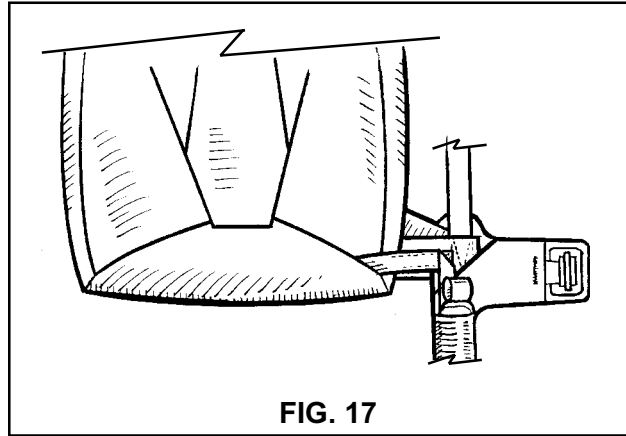

FIG. 17

19. Close the riser covers over the main risers (FIG. 18).

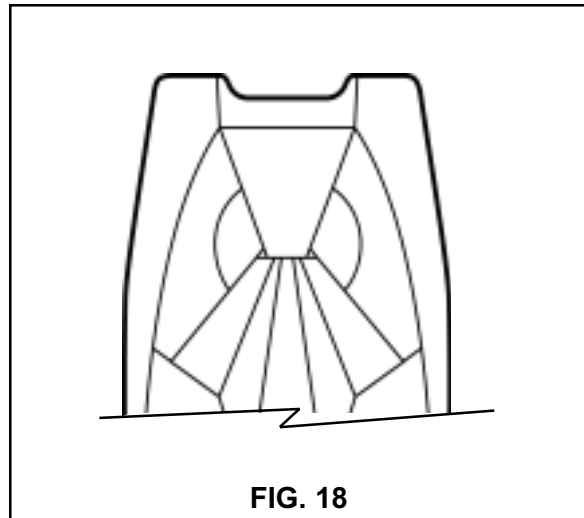
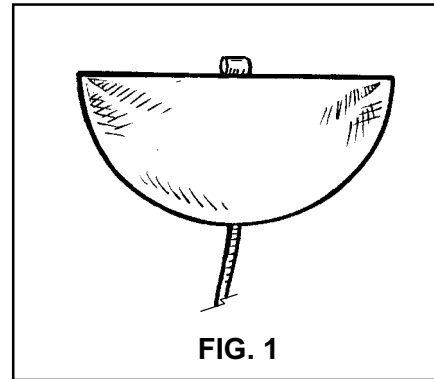

FIG. 18

JAVELINS EQUIPPED WITH A BOTTOM OF CONTAINER (BOC) THROW-OUT PILOT CHUTE

1. Lay the pilot chute out flat with the mesh side up. Fold the excess bridle on top of the laid out parachute and fold the pilot chute in half over the bridle (FIG. 1).



Fold the curved side up about 4" (FIG. 2).

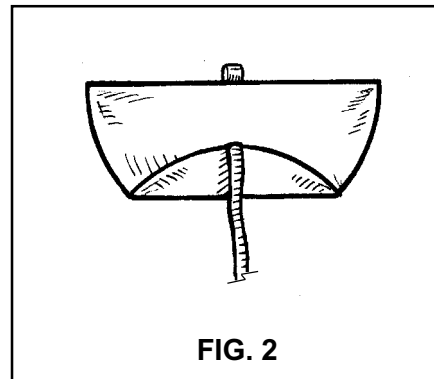

2. Fold the pilot chute into thirds (FIG. 3).

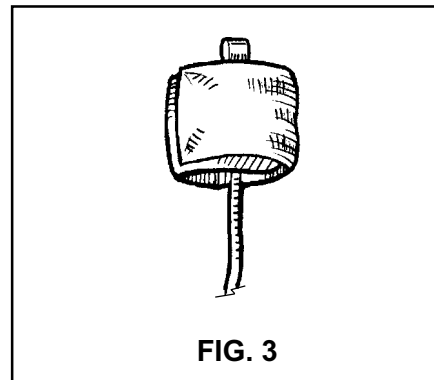

Roll it tightly into a cylindrical shape (the tighter the better) (FIG. 4).

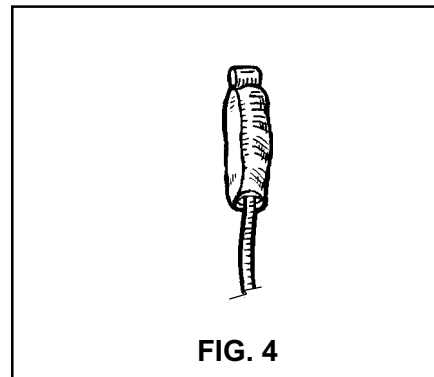

3. Tuck about 12 inches of bridle under the right flap being sure to make it snag proof and secure (**FIG. 5**).

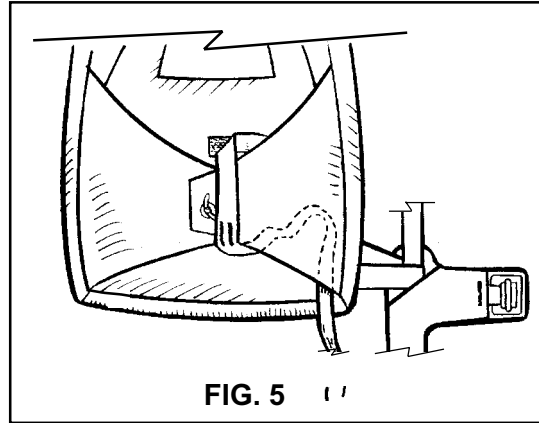

4. Stuff rolled pilot chute completely into pouch making sure the handle sticks out enough for an easy grip. Place any exposed bridle under the bridle cover leading to the spandex pocket. (**FIG. 6**).

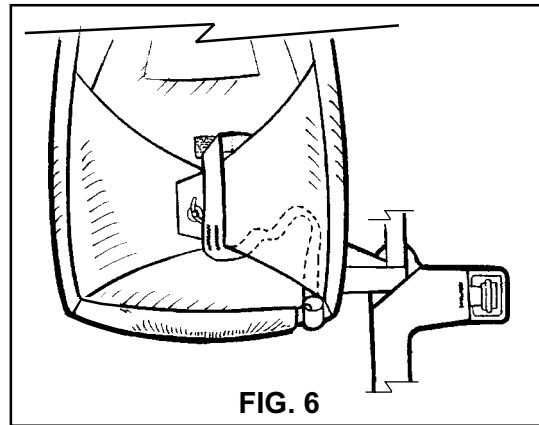

5. Close riser covers over the main risers (**FIG. 7**).

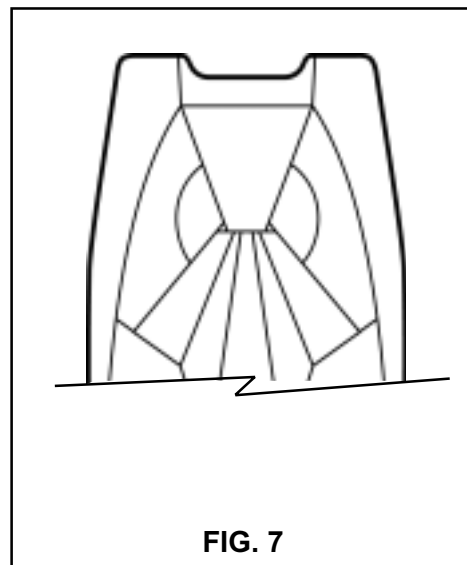

THIS SECTION IS FOR PULL-OUT PILOT CHUTE ONLY

1. Mate the velcro of the pull-out pad with the velcro under the pull-out pad cover. It's located at the right hand corner of the bottom flap (**FIG. 1**).

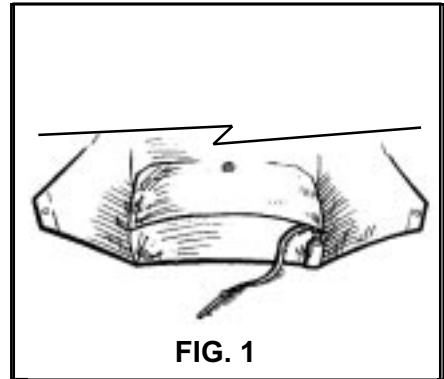

2. Thread the pull-up cord through the closing loop and lay it back across the reserve container temporarily to keep it out of the way. Arrange the bridle in folds 6 to 8 inches long. Lay the folded bridle across the upper part of the bag as shown in (**FIG. 2**). Be sure NOT to tuck these folds down between the bag and the bottom of the reserve container. To do so may retard the action of the pilot chute.

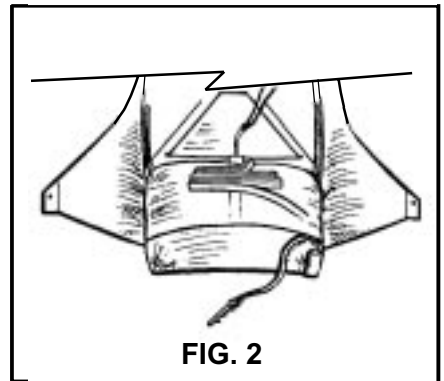

3. Loosely fold the pilot chute and lay it across the bag as shown in (**FIG. 3**).

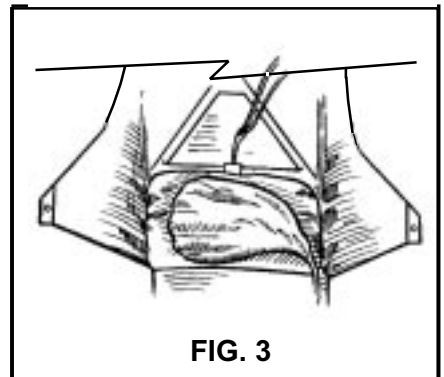

4. Close the bottom flap then the top flap. (**FIG. 4**).

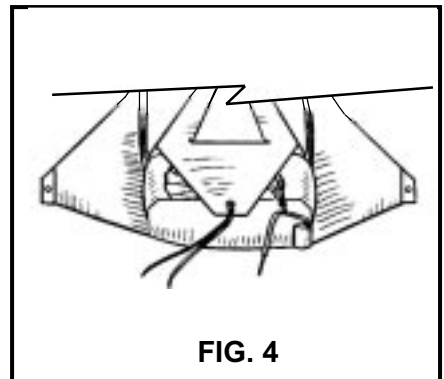

5. Close the right side flap then the left side flap. Secure the closing loop with the pin (FIG. 5).

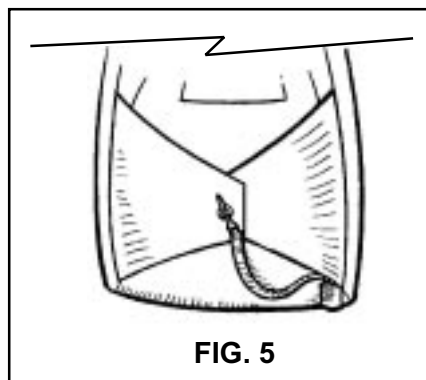

FIG. 5

6. Tuck the slack in the tape under the right side flap (FIG. 6).

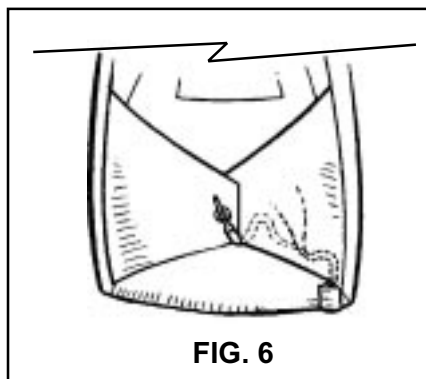

FIG. 6

7. Close the top flap protector by tucking the "tongue" underneath the flaps (FIG. 7).

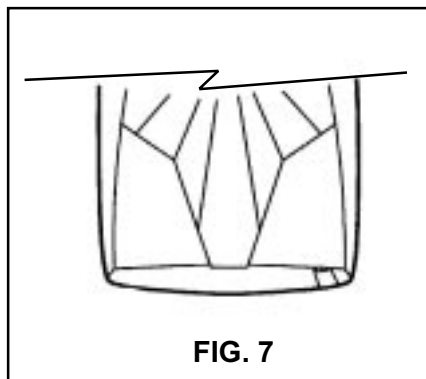

FIG. 7

8. Close the riser covers over the main risers (FIG. 8).

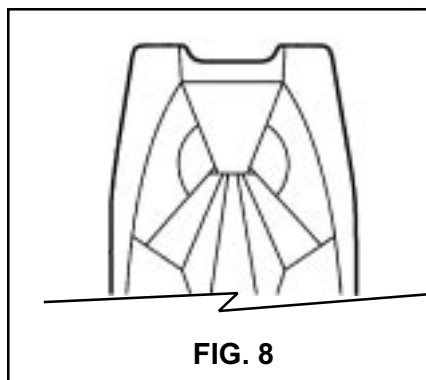

FIG. 8

RAM-AIR RESERVE PACKING INSTRUCTIONS

This chapter deals with the procedures for packing a ram-air reserve canopy into the JAVELIN harness/container system. Assembly and packing of the reserve must be accomplished by an FAA certified Senior Rigger or Master Rigger, or by the manufacturer of the harness/container system.

Helpful Hint: Before starting to pack using your riggers log book copy down type of canopy, S/N and DOM from canopy data panel.

REQUIRED TOOLS:

One adjustable wrench

One temporary pin (preferably with warning flag attached)

One pull-up cord (48" minimum length) (cypres pull-up cord recommended)

One packing paddle or "long bar"

.22 calibre rifle cleaning rod or "T" bar

Two 6 inch strips of 1" velcro loop (with warning flag attached)

Optional tool - knee plate

1. Make a thorough inspection of all components of the reserve parachute
 - a) Reserve pilot chute
 - b) Reserve bridle
 - c) Free-bag ("molar" bag)
 - d) Reserve canopy, lines, slider, connector links
 - e) Harness/container system

2. Follow the canopy manufacturer's directions for the inspection, attachment to risers, routing of control lines, attachment of control toggles, setting deployment brakes and for flaking and folding the reserve canopy.



3. If the manufacturer of the ram-air reserve canopy uses a "conventional" packing method, the canopy should look similar to **(FIG. 1)**, after it has been flaked and folded.

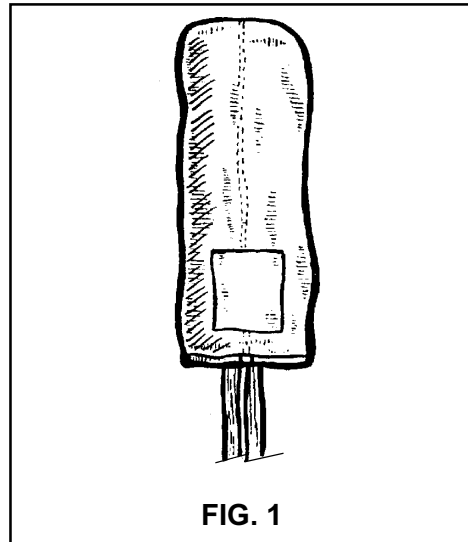

If the manufacturer of the ram-air reserve canopy recommends the "PRO-PACK", the canopy will resemble **(FIG. 2)**. **SUN PATH HIGHLY RECOMMENDS THE "PRO-PACK" FOR ALL RAM-AIR RESERVES PACKED INTO THE JAVELIN HARNESS/CONTAINER SYSTEM.**

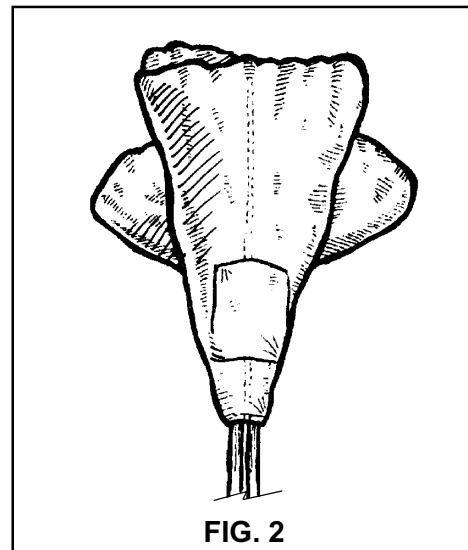

In either case, it will be necessary at this point to spread the top end of the canopy into halves by pushing down into the center from the top and spreading it outward into a "V" shape. **(FIG. 3)**

To keep the canopy symmetrically divided, use the seam in the top of the center cell as a reference. At this point be sure that the slider is as far up as it will go against the slider stops.

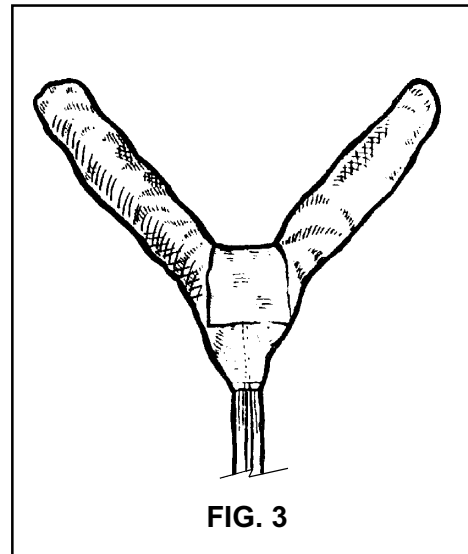

4. Place the reserve deployment bag in the "V" formed by the canopy as shown in (FIG. 4).

Do not use any other deployment bag. Only the JAVELIN "molar" bag may be used in the JAVELIN harness/container system.

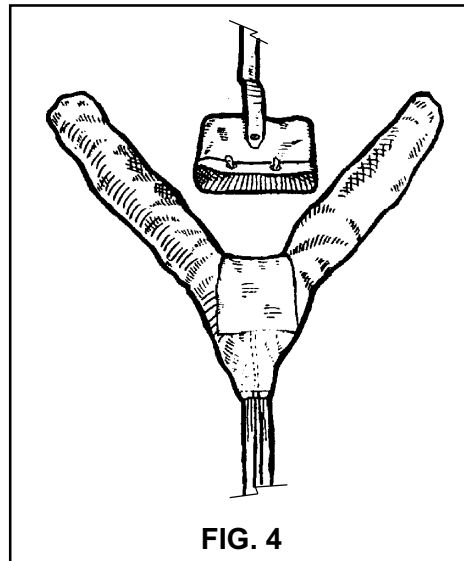

5. "S" fold the bottom of the canopy and slider up on top of itself (FIG 5).

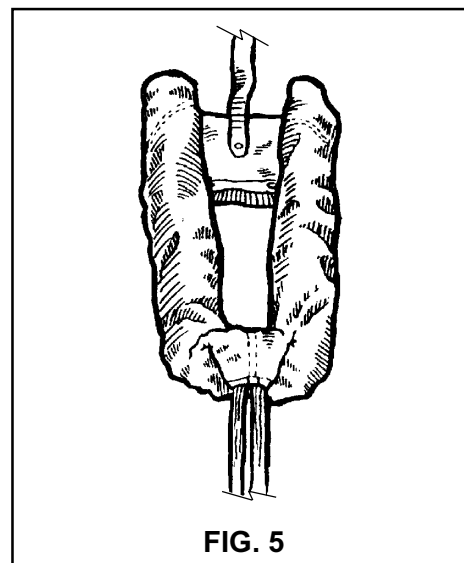

6. With left knee, kneel on the "S" folded portion of the canopy and fold the right hand ear all the way back. Make the fold flush with the top of the canopy (FIG 6).

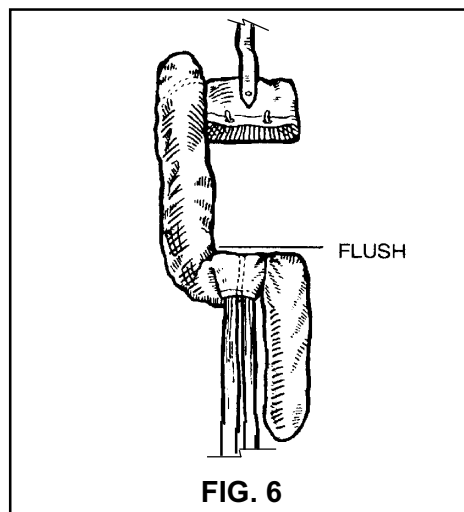

7. Now fold right hand ear forward, making fold flush with bottom of canopy (FIG. 7).

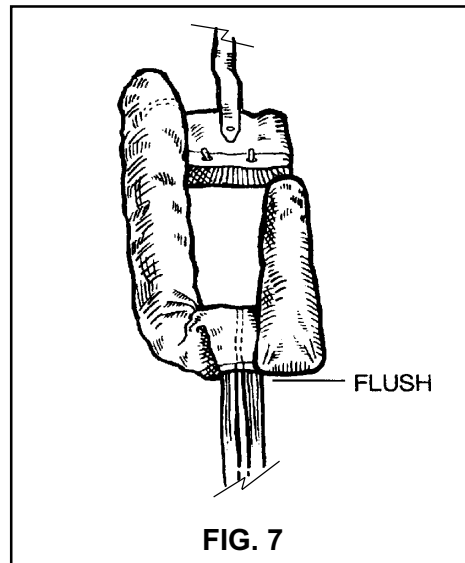

8. Change knee and repeat steps 6 and 7 with left hand ear (FIG 8).

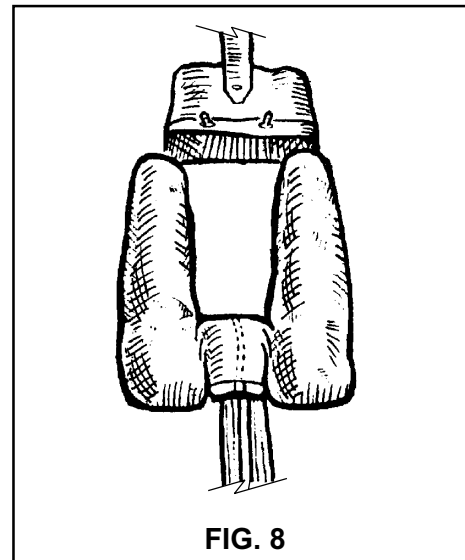

9. Kneel on both ears at bottom of canopy ("S" folded portion) and fold both ears underneath themselves, so that the top of the ear is flush with the top of the canopy (FIG 9).

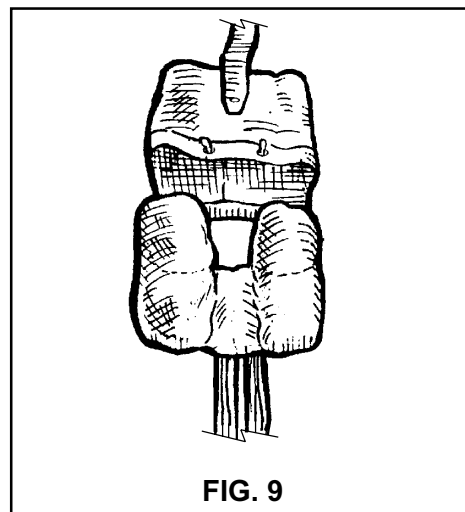

10. Place ears into top corners of the free bag (FIG. 10). Place main bulk of canopy into the remainder of the free bag.

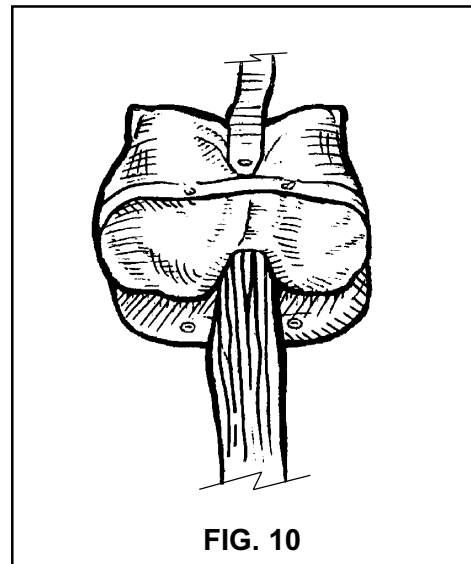

FIG. 10

11. Lock the mouth of the free bag by making two stows with the suspension lines in the "Safety Stow". (This is the loop made of 1/8" shock cord) (FIG 11). Javelin "Safety stow" must be used-use of any other may void TSO.

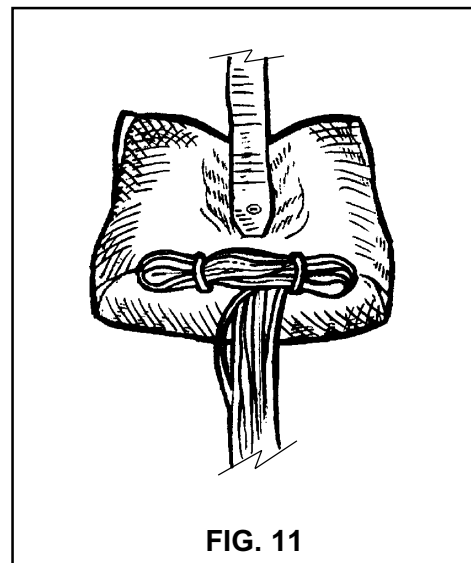

FIG. 11

12. After the two locking stows are made, stow the remainder of the suspension lines (to within 6" of the connector links) in the line-stow pouch on the back of the bag. This is where it is useful to use the velcro strips mentioned in the list of tools. Cover the hook velcro on the pouch with the strips of loop velcro while stowing the lines in the pouch. Make figure of 8 folds with the lines, the width of the pouch. To close the pouch, remove the strips of loop velcro and mate the velcro at the mouth of the pouch, being sure that none of the suspension lines are captured by the closure (FIG 12).

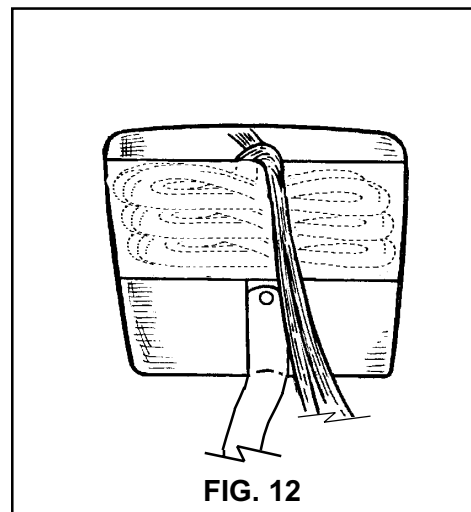

FIG. 12



13. Lay the reserve risers in the container so that the connector links are in the lower corners of the container.

Pass the pull-up cord through the closing loop, then thread it through the grommet in the free-bag. Lay the bag in the container with the line-stow pouch on the under side. Close each side flap in turn, securing the flaps with the temporary pin. Push the tuck flaps under the ears of the bag. "S" fold the bridle evenly up and down both sides of the temporary pin and pull-up cord (FIG. 13).

14. Pass the pull-up cord up through the pilot chute and out through the top plate. This is easily accomplished with .22 calibre rifle cleaning rod, or with the "T" bar. Seat the lower end of the pilot chute on top of the side flaps and bridle, keeping the pull-up cord tight, compress the

pilot chute and lock it with the temporary pin. Now pull all the fabric out from under the top plate so that the pilot chute canopy appears round. At this point check the length of the closing loop. If the pilot chute top plate can rock back and forth or from side to side, the loop is too long. Shorten the loop so that when the pilot chute is compressed and locked with the temporary pin, the top plate will be firmly seated in the "nest" formed by the "molar" shape of the bag and the side flaps.

For pilot chute closure refer to page 29.

HELPFUL HINT

Suggested loop length for cypres closing after setting & stretching to be 2 1/8"

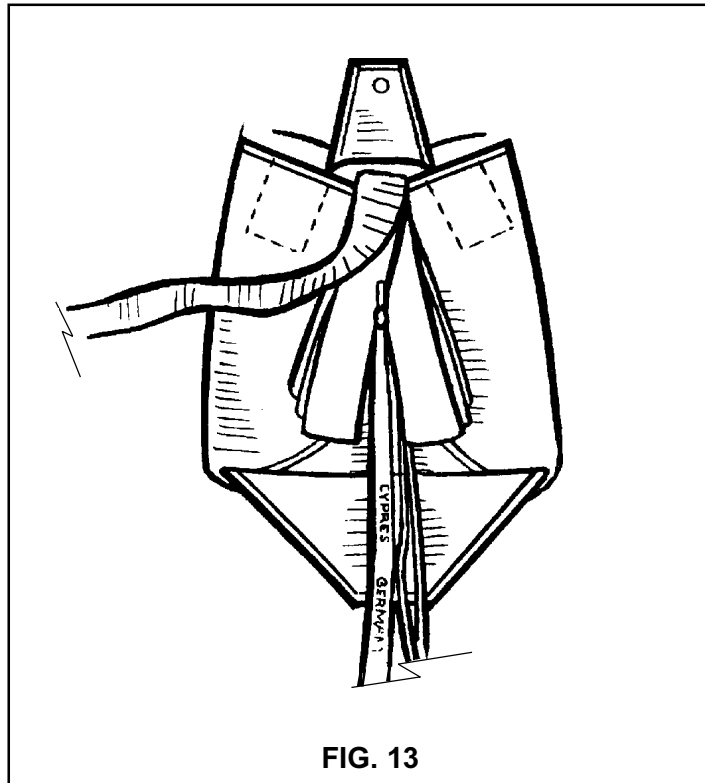

ROUND RESERVE PACKING INSTRUCTIONS

This chapter deals with the procedures for packing a round reserve canopy into the JAVELIN harness/container system. Assembly and packing of the reserve must be accomplished by an FAA certified Senior Rigger or Master Rigger, or by the manufacturer of the harness/container system.

Helpful Hint: Before starting to pack using your riggers log book copy down type of canopy, S/N, DOM from canopy data panel.

REQUIRED TOOLS:

One adjustable wrench or flat head screwdriver
One temporary pin (preferably with warning flag attached)
One pull-up cord (48" minimum length) (Cypres pull-up cord recommended)
One packing paddle or "long bar"
.22 calibre rifle cleaning rod or "T" bar
Optional Tool - Knee plate

1. Make a thorough inspection of all components of the reserve parachute:
 - a) Reserve pilot chute
 - b) Reserve bridle
 - c) Reserve canopy, lines, connector links
 - d) Harness/container system

2. Attach the bridle to the apex of the reserve canopy. The smaller loop of the bridle should be used at the apex and the loop should be tacked securely with enough slack so that the loop will not bind the apex lines. The apex lines must be able to move freely through the bridle attachment (**FIG. 1**).

The large loop of the bridle must then be attached to the pilot chute.

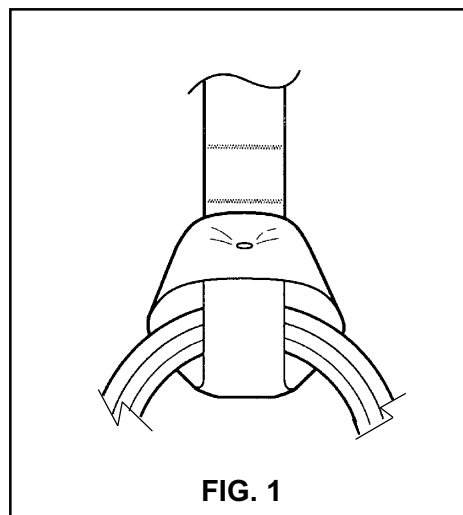

3. Follow the canopy manufacturer's directions for the inspection, attachment to risers, routing of control lines (if present) and for flaking the reserve canopy.

4a. If the canopy is equipped with a full diaper, all stows of the suspension lines will be made on the diaper. Do this in accordance with the canopy manufacturer's directions. Lay the risers in the reserve container so that the connector links are in the lower corners (FIG. 2) and go to STEP 5.

4b. If the reserve canopy has no diaper, or is equipped with only a partial diaper, the suspension lines must be stowed in the container. Lay the risers in the container so that the connector links are in the lower corners (FIG. 2) and make the first stow of suspension lines in the lower left corner. Continue upward, making the stows the full width of the pack tray (FIG. 3).

5. Place the skirt (or diaper) of the canopy in the lower left corner of the reserve container. If the diaper is not as wide as the container, make a short fold in the right side to equalize the bulk (FIG. 4).

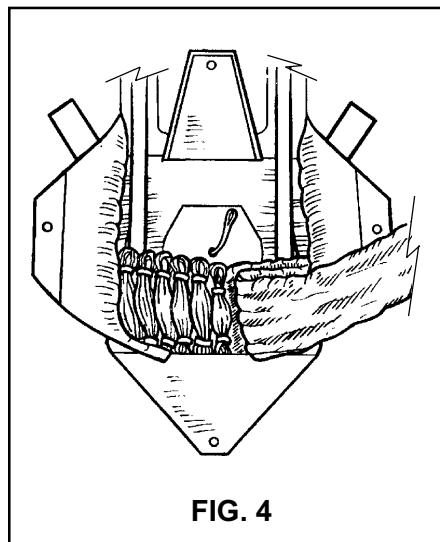
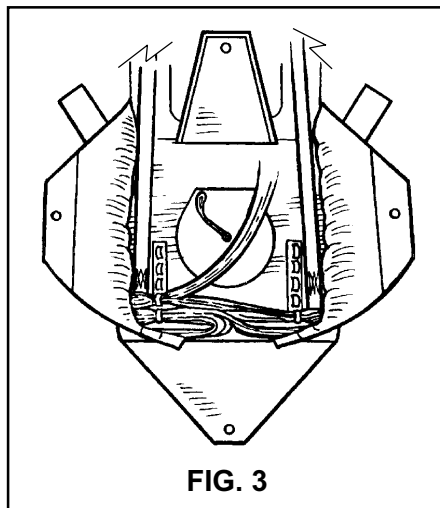
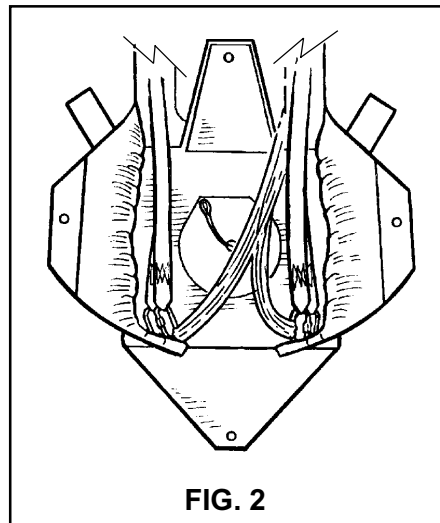

6. Fold the canopy up and down the right side of the container, then make a fold across the bottom of the container, on top of the diaper or skirt (**FIG. 5**).

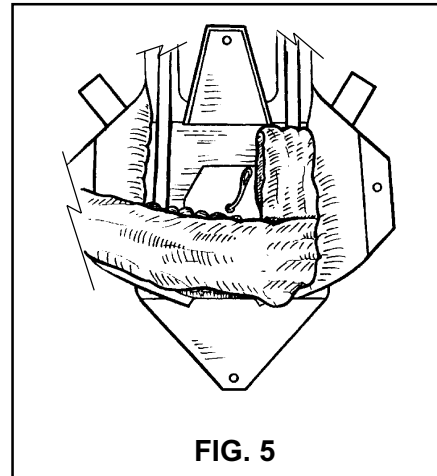

FIG. 5

7. Make two folds up and down the left side of the container, keeping the bulk away from the center as much as possible. The rigger may at this point make another fold across the bottom in order to distribute the bulk evenly side to side (**FIG. 6**).

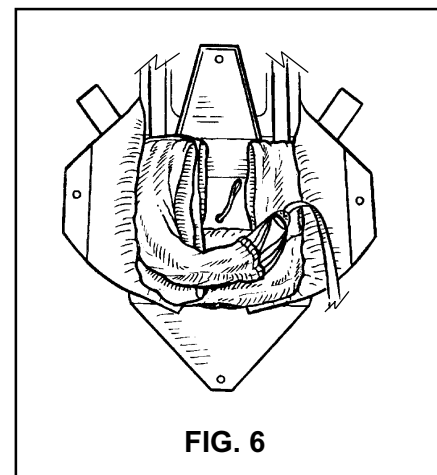

FIG. 6

The object is to form a "U" shaped stack with the canopy so that the pilot chute will seat itself in the "nest" formed by the side flaps after they have been closed.

The distribution of bulk may vary with the size of the canopy or the shape of the container and it is left to the rigger's discretion how many folds to make on each side or how many times the canopy may be folded across the bottom of the container. As long as the stack is basically "U" shaped and the bulk of the stack is kept away from the center of the container, the pack is more likely to be correctly shaped after the flaps have been closed.



A HELPFUL HINT:

Be sure that the lower corners of the reserve container are filled as you fold the canopy into the container. If there is slack in the lower corners, it may be difficult to close the container or to make the container look neat after it has been closed.

ONE NOTE OF CAUTION:

Do not stuff the apex of the canopy down into the lower corner of the reserve container. Doing so might delay (or even prevent) extraction of the apex by the pilot chute.

8. Thread the pull-up cord through the closing loop and close each side flap in turn, routing the bridle out the side of the container. Try to keep the bulk of the canopy away from the center of the container while closing the side flaps. Secure the side flaps with the temporary pin (**FIG. 7**). Then push the tuck flaps in under the folded canopy at the upper edge of each side flap.

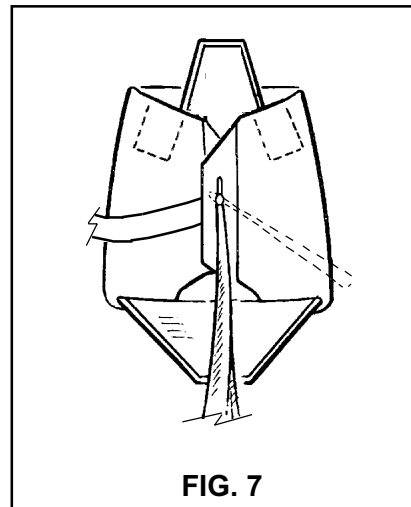

FIG. 7

9. Pass the pull-up cord through the pilot chute and out through the top plate. This is easily accomplished with the .22 calibre rifle cleaning rod or with the "T" bar, but easier than without!! Seat the lower end of the pilot chute on top of the side flaps, and keeping the pull-up cord tight, compress the pilot chute and lock it with the temporary pin. Now pull all the fabric out from under the top plate so that the pilot chute canopy appears round. At this point check the length of the closing loop. If the pilot chute top plate can rock back and forth or from side to side the closing loop will need to be shortened. Shorten the loop so that when the pilot chute is compressed and locked with the temporary pin, the top plate will be firmly seated in the "nest" formed by the "U" shape of the stacked canopy.

10. Fold the bridle of the round canopy in accordion folds across the bottom of the container on top of the side flaps. The width of the folds will vary with the width of the container; a simple rule-of-thumb is: "make the folds as wide as possible, but not so wide as to be seen after the bottom flap has been closed".

11. Roll or fold the pilot chute fabric at the top of the pilot chute parallel with the top of the container and push this roll under the top plate of the pilot chute. Draw the rest of the pilot chute fabric down the sides of the pilot chute top plate pushing the excess fabric under the pilot chute top plate as you go (FIG. 8).

12. Fan out the pilot chute fabric, so that it extends wider than the bottom flap. Be sure to keep the point of the fan narrow and tight to the middle of the bottom of the pilot chute top plate. Close the bottom flap and secure it with the temporary pin. (FIG. 9).

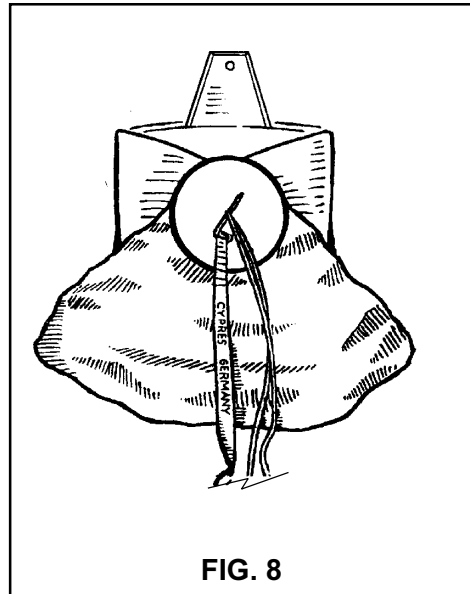

FIG. 8

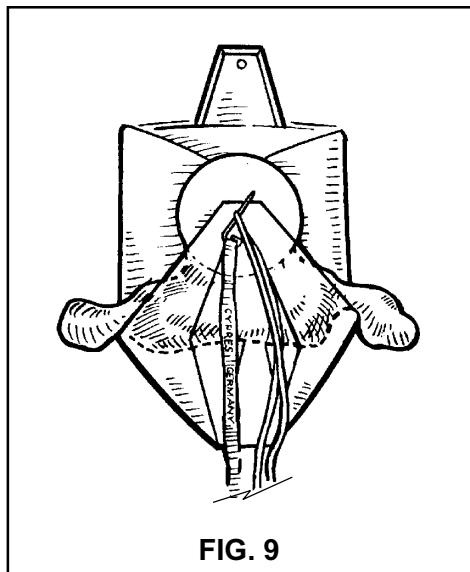

FIG. 9



13. Close the top flap and secure it with the ripcord pin. (Be sure that your temporary pin is accounted for at this time!)

14. Using the packing paddle push the fanned out pilot chute fabric under the bottom closure flap (ensure fabric is over bridle and not under it) to leave a clean and tidy pack job. Seal the reserve container and log the work done on the packing data card and in your rigger's logbook. Place the completed data card in the pocket provided on the underside of the reserve top flap cover. Secure the top flap cover over the top flap by inserting the tongue on each side under the top flap and insert the bottom of the top flap into the protector pocket (**FIG. 10**).

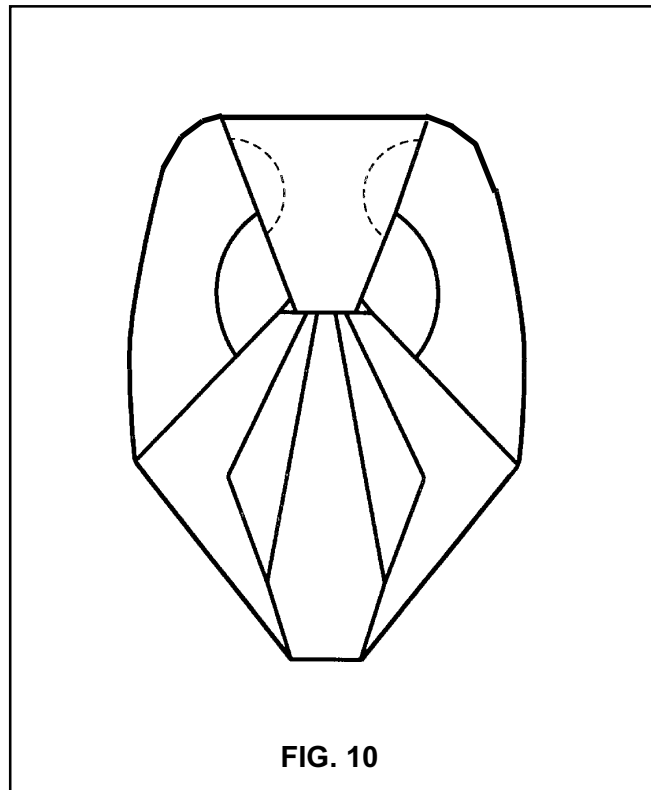

FIG. 10

15. COUNT YOUR TOOLS!

JAVELIN RESERVE STATIC LINE

CAUTION

Although the *Reserve Static Line* is considered to be very dependable, it is only a backup and should never be relied upon entirely for activation of the reserve. In the event of a breakaway or cutaway, the jumper should follow through by pulling the reserve ripcord handle as if there were no *Reserve Static Line*.

It must also be understood that the *Reserve Static Line* will NOT operate in the event of a TOTAL malfunction of the main.

In October 1990, Sun Path adopted the Reserve Static Line (RSL) as a standard feature on all JAVELIN harness/container systems. The RSL is a simple, inexpensive but effective way of assuring that the reserve ripcord will be pulled immediately after disconnecting from the main canopy. The RSL is also designed not to interfere whatsoever with manual activation of the reserve.

For the very few cases where immediate reserve activation may not be desired, the JAVELIN RSL features a quick-release which can be used to disconnect the RSL. This quick-release consists of a snap-shackle which is normally attached to a small ring on the inboard side of the left main riser. Release of the snap-shackle is accomplished by a quick tug on the red ribbon attached to the release ring.

Some jumpers feel that the RSL should not be connected during Canopy Relative Work, preferring to disconnect from the main and then fall free of a "wrap" before deploying the reserve. Also, if winds are high, the jumper may disconnect the main canopy after landing to avoid being dragged. In this case the quick-release can be used prior to landing to prevent an unnecessary activation of the reserve.



ASSEMBLING THE RSL

There are two small rings mounted on the reserve top flap near the end of the reserve ripcord housing. After installing the reserve ripcord in the housing, the cable must be passed through the ring nearest the housing. It is then passed through the ring on the end of the Reserve Static Line, then through the ring nearest the grommet in the reserve top flap (**FIG. 1**).

It is important to assemble the cable with the rings in this exact order, the ring nearest the grommet keeps the cable in line with the pin during activation and the ring nearest the housing prevents the ring of the RSL from being caught on the end of the housing.

After the reserve container is closed and the rigger's seal is installed, the Reserve Static Line must be routed out from under the reserve pin cover at the upper left as shown in (**FIG. 2**).

The velcro of the RSL should be mated to the velcro on the left reserve riser to bring the RSL over the shoulder.

Then the snap-shackle can be connected to the small ring behind the inboard side of the left main riser (**FIG. 3**).

There should be enough slack in the RSL so that the main riser can be pulled in any direction without putting any tension on the reserve riser. Any slack in the RSL near the reserve pin cover can be tucked under the reserve top flap. (This may vary with the size of the rig.)

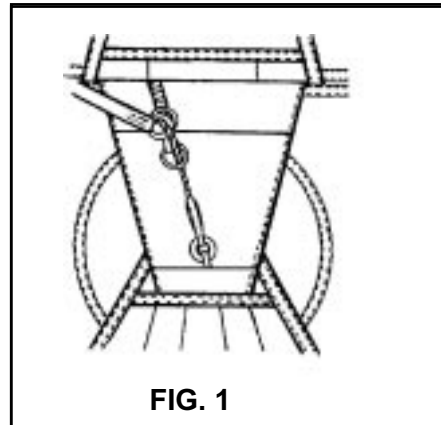

FIG. 1

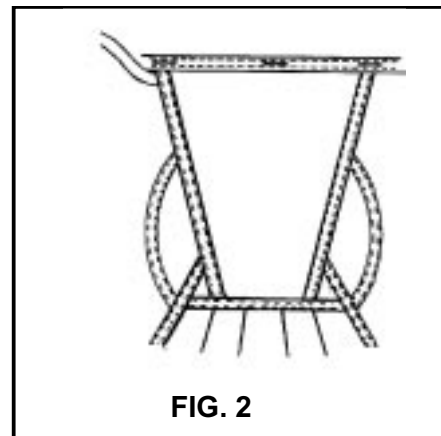

FIG. 2

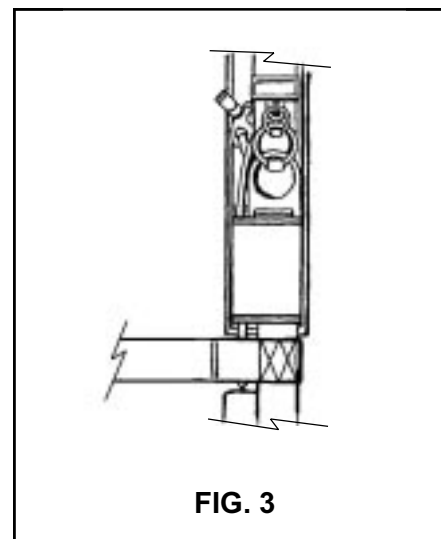

FIG. 3

THE 3-RING RELEASE CABLE LENGTHS

After the cables have been installed in the housings of your Javelin harness/container there should be 5 1/2" of excess cable on the user's left-hand and right-hand side. These measurements are based on extensive testing and should not be altered in anyway to change the correct operation of the RSL.

THE 3-RING RELEASE SYSTEM

The 3-Ring Release System was invented by the Relative Workshop in 1976. It was the first practical release that allowed parachutists to jettison their main canopies in one motion by simply pulling a single handle. Not only is the 3-Ring easier to operate than previous canopy release systems, it is also more reliable. Failures of a properly built and assembled 3-Ring system are virtually unknown. Once the main is jettisoned, the only things left on the harness are two smooth rings that cannot snag a deploying reserve. Some other popular release systems can-and have-interfered with the deploying reserve.

GETTING TO KNOW THE 3-RING

Knowing how the 3-Ring release works will help you assemble and inspect it properly. Begin by peeling the release handle from the Velcro on the harness. Peeling, rather than pulling, makes it easier to separate the handle from the webbing. Look behind the risers near the harness and observe the movement of the yellow cable as you pull the handle. When the cable clears the white loop, the release is disengaged. Now slowly pull one of the risers off the harness. As you pull, you'll notice that the white loop gets pulled through the grommet by the action of the smallest ring. Each ring forms a lever with a ten-to-one mechanical advantage as it passes through the other. A force of 1,000 lb. on the large harness ring exerts a force of only ten pounds on the white loop. (Opening shock usually totals about 1,000 lb., or 500 lb. on each riser).

NOTE:

Sun Path does not recommend the use of "Reverse Risers" on Javelin Harness and Containers.



Because of the mechanical advantage provided by the 3-Ring design, only a force of approximately a pound on the top ring keeps the release together. That's why it's important to keep foreign matter like bits of grass and sticks out of the 3-Ring assembly. A small stick in the white loop could prevent a riser from releasing. It is also important to understand one of the properties of the nylon components of the system. When nylon stays in the same position for a long time, it begins to conform to that position, or take a "set". If the 3-Ring release system stays assembled for too long, the nylon can become so stiff that the low drag from a malfunction (such as a streamer) won't pull the riser off the ring. The 3-Ring release system must be disassembled, flexed and inspected every month. Procedures for this are listed in the maintenance chapter of the manual.

ASSEMBLY

Before assembling the 3-Ring release, make sure the risers aren't twisted or reversed. Lay the JAVELIN face down, as you would to pack it.

1. Thread the cable into its housing and stick the cut away/release handle to the harness. The handle should be positioned as close to the ends of the housings as possible so that no cable is exposed.

2. With the rings of the riser facing toward the floor, pass the ring on the end of the riser through the large harness ring from above. Fold it back toward the canopy and risers (**FIG 1**).

3. Thread the smallest ring through the middle ring in the same way, but make sure it doesn't pass through the large ring (**FIG. 2**).

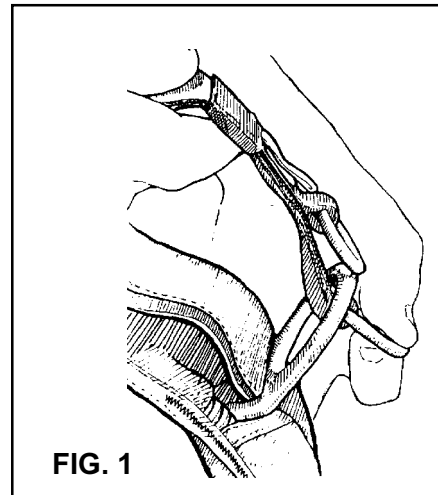

FIG. 1

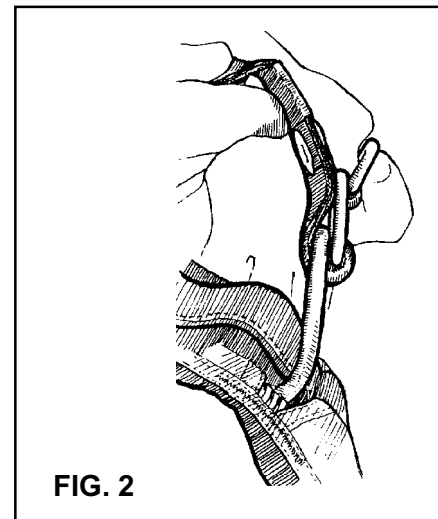
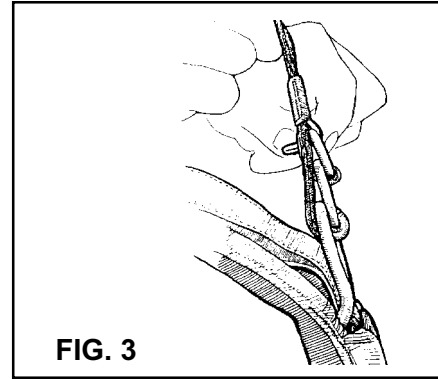
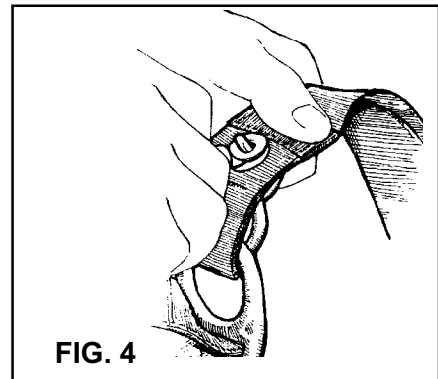

FIG. 2

4. Bring the white loop over the small ring only and then through the riser grommet so it pokes out the back of the riser (**FIG 3**).



5. Continue threading the white loop through the grommet on the end of the cable housing. The flat side of the cable housing grommet should be against the riser (**FIG 4**).



6. Thread the yellow cable through the white loop, making sure the loop isn't twisted (**FIG 5**).

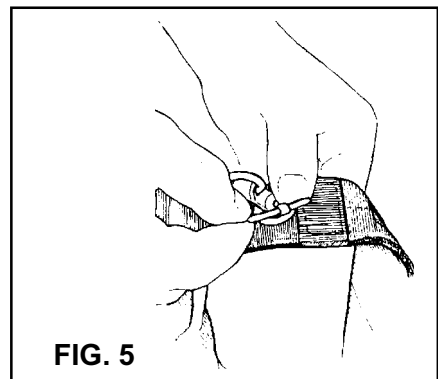

7. Be careful with the cable so you don't bend it too sharply or kink it (**FIG 6**).

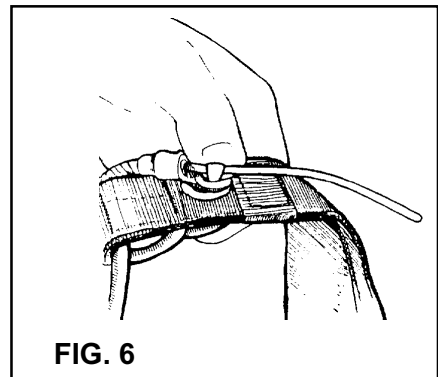

8. Insert the free end in the channel on the back of the riser (**FIG. 7**).
Repeat the above steps with the other riser.

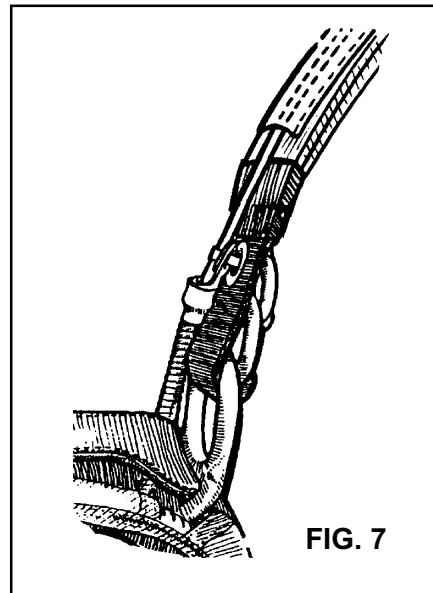

REQUIRED PERIODIC MAINTENANCE FOR THE 3-RING

The Booth 3-Ring Release System has been in use for many years with excellent results. Although the system is as durable as the rest of the harness/container assembly, it requires periodic maintenance and inspection to ensure proper operation. Generally it is NOT recommended that the risers be attached to the harness when new and "forgotten." Like all skydiving gear, the 3-Ring Release should be carefully inspected and operated on a regular basis. The procedures below should be done at least every month. This is especially important if the rig has not been used for a month or more, such as during the winter. Immediate inspection is required if it has been subjected to some abuse such as a drag across the runway, a water landing or exposure to a lot of dust or sand.

1. Every month operate the 3-Ring release system on the ground. Extract the cable completely from the housings and disconnect the risers.
2. While the system is disassembled, closely inspect it for wear. Check the white locking loops (the ones that pass over the smallest ring and through the grommet) to be sure they are not frayed.
3. Check the Velcro on the breakaway handle and main lift web to be sure it is clean and adequately holds the handle.
4. Check the cable ends for a smooth finish. The ends are finished at the factory to have a smooth, tapered surface. This prevents the cable from hanging up in the loop. Check the cable ends and consult a rigger or the manufacturer if a burr or "hook" is present.
5. Check the stitching, including that which holds the large rings to the harness.
6. Pull downward on the housings. They shouldn't move downwards more than 1/2 inch.

7. Take each riser and vigorously twist and flex the webbing near where it passes through each ring. The idea is to remove any set or deformation of the webbing. Do the same thing to the white loop. **(FIG. 1)**
8. Check the housings for dents or other obstructions. Use the cable to do this.
9. Clean and lubricate the release cable with a light oil such as a "3-in-1" brand. Put a few drops on a paper towel and firmly wipe the cable a few times. A thin, invisible film should remain--too much will attract grit and dirt, or the oil could become tacky in cold weather. Too much oil will require more force to extract the cable during a breakaway.
10. Inspect the fittings at the end of each housing. If one of these fittings were to come off the housing, a riser might release prematurely.
11. If any wear is found, consult a rigger or the manufacturer before using the JAVELIN.
12. Reassemble the system. Double check it. Make sure the risers aren't reversed. It's important to maintain the system even more frequently in humid, muddy or freezing conditions. If the JAVELIN becomes immersed in mud or muddy water, clean the 3-Ring release system with a mild solution of soap and water. Any rusted components must be replaced.

BEFORE USING THE JAVELIN

1. Read and understand this manual and be qualified by proper instruction for sport parachuting activities.
2. Check both 3-Ring releases to see that they are correctly assembled and check to see the release handle is securely attached (Velcro) to the main lift web.
3. Check the main container closure for correct pin position and correct routing of the bridle. The little velcro tab on the bridle must be mated to the one on the top flap.
4. Check the reserve container for correct pin closure and routing of the ripcord. Be sure the reserve ripcord handle is well seated in its velcro pocket.
5. The main pilot chute must be protected by its pouch, but the handle must be easily accessible and or visible.

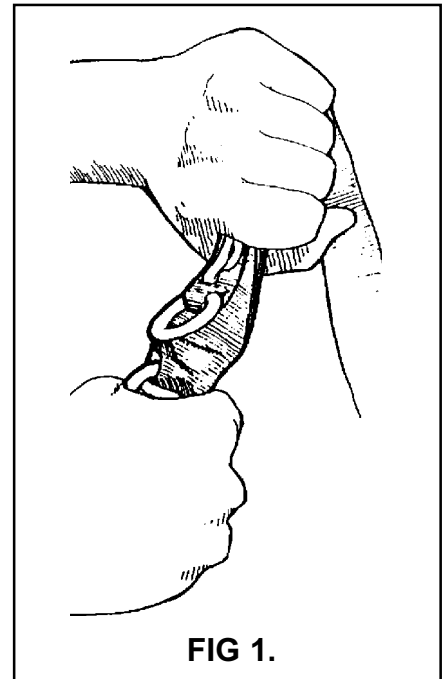

DONNING THE JAVELIN

When lifting the JAVELIN, grasp the main lift web between the large harness ring and the chest strap. Put the rig on as you would a jacket, settling the yoke across the shoulders. Step through the leg straps, **being sure they aren't twisted**, then thread the chest strap through its friction adapter (adjustor) and tighten it to where it is comfortably snug. Be sure it has NOT been threaded through the reserve ripcord handle.

Tighten the leg straps until they are comfortably snug and stick the free end of the strap down into the leg pad or in an elastic keeper. It is important to secure these free ends; a loose free end can easily be mistaken for a deployment handle.

RING HARNESS ADJUSTMENT

If your Javelin is equipped with a ringed harness, to insure a proper and comfortable fit, it is very important that you tighten the chest strap first. By first tightening the chest strap very snugly, this will allow full arm and shoulder movement. Next tighten the leg straps until they are comfortably snug. (FIG. 1)

Be sure all the friction adapters are correctly threaded. The webbing must pass under the adapter (next to the jumper's body) and come up through the frame above the moveable bar, then back around the moveable bar and under the end of the frame. If the webbing is routed in any way other than what is shown in

(FIG. 2) or (FIG. 3). **IT MAY NOT HOLD!**

(1" chest strap) Fold the free end of the chest strap back onto the short side and stow the excess in the 1" elastic keeper (FIG. 4).

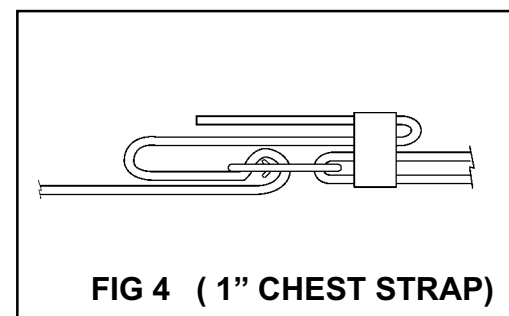
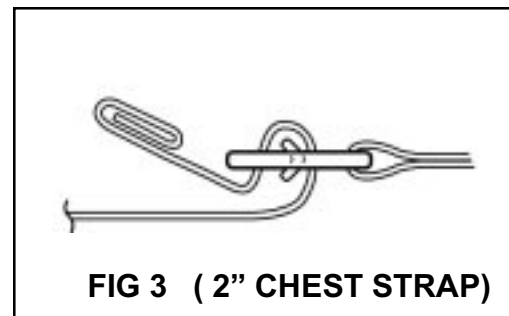
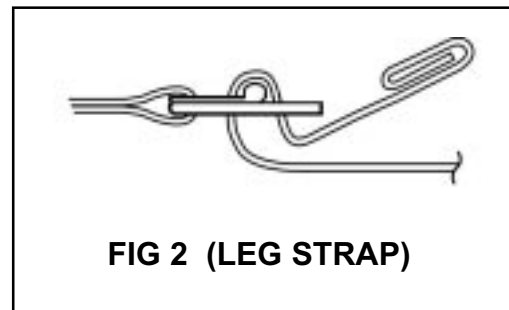
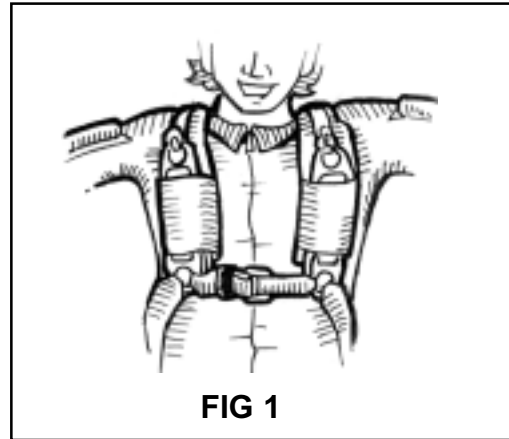

This section is not a full course of instruction on how to deal with emergencies. It is meant only to explain the function of the JAVELIN harness/container system. Learning the proper procedures and deciding when, or if, to use them is the responsibility of the jumper, who must be thoroughly trained by an experienced and qualified instructor before attempting to make a parachute jump.

MAIN DEPLOYMENT

BEFORE JUMPING

The pouch for the main pilot chute is located at the right hip on the outside of the right leg pad or on the bottom of the main container. When the pilot chute is packed correctly, the handle should be visible and easy to grasp at the top of the pouch. (It is very important that the jumper familiarize himself with all handles and activation devices on his rig before jumping). Practice locating the handle, grasping it and extracting the pilot chute. Then go through the same procedure without looking at it. This should be done under the supervision of an instructor. The pilot chute pouch location on some JAVELIN's will not allow the handle to be visible. i.e. JAVELIN's fitted with B.O.C. (Bottom of Container) or pull out.

IN THE AIR

In a flat and stable position face-to-earth, grab the pilot chute handle and in one motion, extract the pilot chute from the pouch and vigorously throw it STRAIGHT OUT to the side, placing it in clean air. If you are in the air with other jumpers, the wave-off should be done before extracting the pilot chute. Waving off with the pilot chute in hand may cause a premature opening of the container.

RESERVE DEPLOYMENT

PARTIAL MALFUNCTION

A partial malfunction occurs when the canopy has come out of the container, but has not opened properly. Most jumpers are now trained to jettison (disconnect) the main canopy before activating the reserve if the partial malfunction is serious enough to warrant emergency procedures. Disconnecting from the main is called a "breakaway" or "cutaway" and it is done to prevent the entanglement of the reserve with the main.

PROCEDURE

Look down and locate both the cutaway/release handle (on right main lift web) and the reserve ripcord handle (on left main lift web). Grab the cutaway/release handle and peel it away from its velcro mount. Pull it vigorously downward and outward as far as the arm will reach. Throw it away and then grasp the reserve ripcord handle. Pull it vigorously downward and outward as far as the arm will reach. It must be emphasized that it is the jumper's responsibility to decide whether any emergency procedure is appropriate and to decide whether he has enough time or altitude to perform it. Obviously if the jumper decides that he is too low to perform a breakaway, he should simply activate the reserve.



TOTAL MALFUNCTION

A total malfunction occurs when the main canopy is still in the container after an attempt has been made to activate it. This may occur if the pilot chute cannot be extracted from its pouch, or if the pilot chute is inflated but cannot open the container. It is generally considered best when presented with a total malfunction to simply pull the reserve ripcord without breaking away from the main canopy. A total malfunction always leaves the jumper falling at high speed and breaking away from a canopy that is still in the container may waste precious time and altitude.

PROCEDURE

Look at the reserve ripcord handle (the metal handle or soft handle just below the chest strap on the left main lift web), grasp it with both hands and pull it downward and outward with all your strength and as far as you can reach. It is usually considered best to be in a stable position somewhat head-high when deploying any canopy, but if time and altitude are running out, body position is not as important as getting the canopy out!

DEAR JAVELIN OWNER,

It is the goal of SUN PATH PRODUCTS, INCORPORATED to produce and sell the best sport parachute equipment that can be manufactured with today's materials and technology. In this effort, it is important that we obtain all the feedback from our customers that we can. We would like for you to share with us any observations, problems, suggestions, etc., that you may have. Our primary concern is of course the SAFETY and DEPENDABILITY of the JAVELIN harness/container system. After that, ***your satisfaction comes first.***

We thank you for your choice of the JAVELIN and we hope for your continued confidence in SUN PATH PRODUCTS INC.

BLUE SKIES and SAFE DIVES,
SUN PATH PRODUCTS, INC.



Appendix A: Maintenance and Repairs

Applicable to all Javelin and Javelin Odyssey harness/container systems, sport and student.

Your Javelin/Javelin Odyssey harness container system is built with the latest technology and most up to date manufacturing methods.

QUALIFIED PERSONELL:

It is strongly recommended that all major repairs to Javelin/Javelin Odyssey harnesses and container systems be made at the manufacturers' facility in Zephyrhills, Florida.

AUTHORIZATION:

Javelin/Javelin Odyssey harness/container systems are certified under TSO c23d. The TSO label is located under the reserve pin cover flap or inside the pocket on the yoke if the rig has a clear reserve pin cover. If this label is not present or has been removed **DO NOT PACK THE RIG.** **Removal of the TSO label voids the TSO and all certification approvals.**

IF THERE ARE ANY VISIBLE SIGNS OF WEAR OR DAMAGE, HAVE YOUR RIG THOROUGHLY INSPECTED BY A CERTIFIED PARACHUTE RIGGER OR OUR MANUFACTUREING FACILITY IN ZEPHYRHILLS, FLORIDA BEFORE NEXT USE.

LIMITS AND GUIDELINES FOR DAMAGE:

Limits and guidelines for webbing are applicable to all sections of the harness. To include reserve risers, main lift web, lateral/diagonal and leg straps.

At every repack cycle, the entire harness/container system should be thoroughly inspected. Completion of this inspection and annotation of an A/I/P or A/I/R on the packing data card implies that the certifying party has inspected and deemed the harness, container and all applicable components to be airworthy and ready for use.

A visual inspection of the harness webbing and hardware should be conducted before each use to determine whether or not it is showing signs of abrasion, fraying, nicks, unusual wear and tear or any other visible damage to any part of the webbing and or hardware damage that will degrade its strength. Refer to the following grading list as a guideline for determining webbing wear.

■ **Grade 1** Like new, does not need replacement. See Fig. 1

■ **Grade 2** Minor Hook and Loop type abrasion.
Minor wear due to normal use. Replacement optional, make note to inspect specific area on every repack cycle. See Fig. 2

■ **Grade 3** Any damage to selvedge edges of harness webbing. Broken or missing harness stitching. Mandatory replacement or repair. See Fig. 3

Figure 1 **Grade 1**

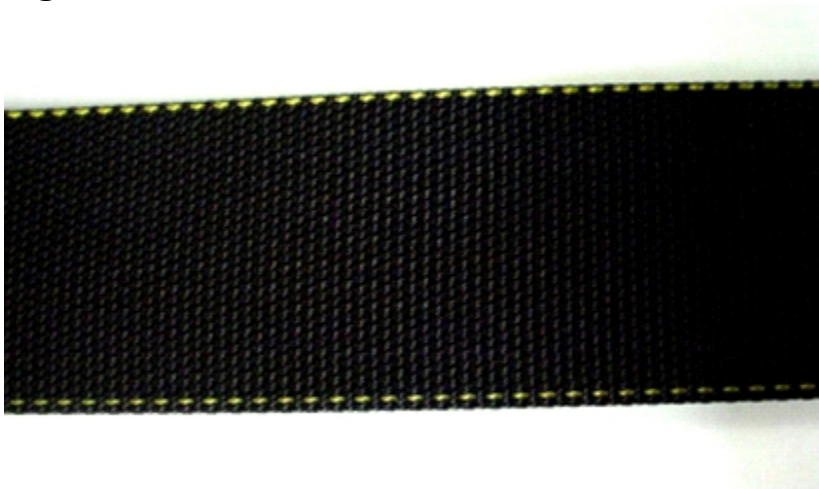
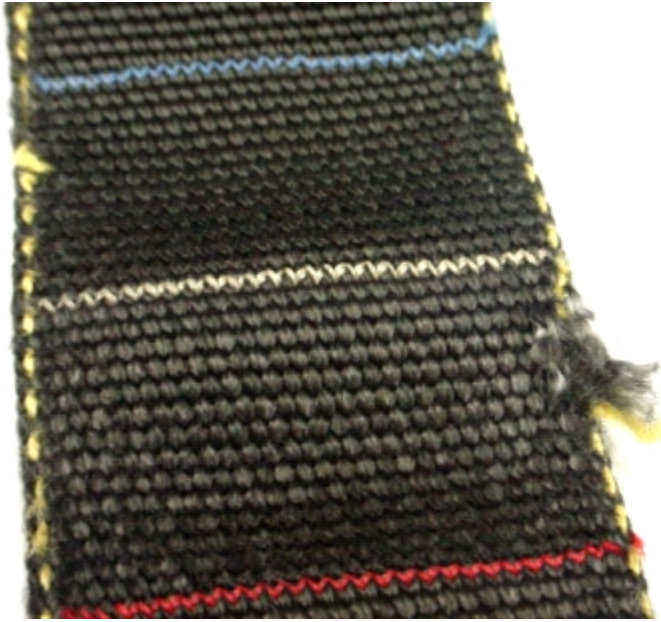

Figure 2 **Grade 2**



Figure 3 Grade 3



STORAGE:

Textiles and other materials used in the manufacture of parachute equipment to include harness/container systems are sensitive to the following environmental elements.

- Water/humidity
- Salt water
- Ultraviolet rays (Sunlight)
- All petroleum based products (oil, grease)
- Rodents, pests
- Smoke
- Excessive heat
- Chlorine (bleach)
- Acid

While the parachute equipment is not in use it is recommended to store the gear in a proper gear bag and in a room where the temperature and humidity is maintained.